



Level



Pressure



Flow



Temperature

Liquid
Analysis

Registration

Systems
Components

Services



Solutions

Technical Information

Waterpilot FMX21

Hydrostatic level measurement

Reliable and robust level probe with ceramic measuring cell

Compact device for level measurement in fresh water, wastewater and saltwater, communication via HART



Application

The Waterpilot FMX21 is a pressure sensor for hydrostatic level measurement.

Endress+Hauser offers three different versions of the FMX21 sensor:

- FMX21 with a stainless steel housing, outer diameter of 22 mm (0.87 inch): Standard version suitable for drinking water applications and for use in bore holes and wells with small diameters.
- FMX21 with a stainless steel housing, outer diameter of 42 mm (1.66 inch): Heavy duty version, easy clean flush-mounted process diaphragm. Ideally suited for wastewater and sewage treatment plants.
- FMX21 with a coated housing, outer diameter of 29 mm (1.15 inch): Corrosion resistant version generally for use in saltwater, particularly for ship ballast water tanks.

Your benefits



- High resistance to overload and aggressive media
- High-precision, robust ceramic measuring cell with long-term stability
- Climate proofed sensor thanks to completely potted electronics and 2-filter pressure compensation system
- 4 to 20 mA with superimposed HART 6.0 output signal
- Simultaneous measurement of level and temperature with optionally integrated Pt100 temperature sensor
- Accuracy
 - Reference accuracy $\pm 0.2\%$
 - PLATINUM version $\pm 0.1\%$
- Automatic density compensation to increase accuracy
- Usage in drinking water: KTW, NSF, ACS
- Approvals: ATEX, FM, CSA
- Marine certificate: GL, ABS, LR, DNV
- Extensive range of accessories provides complete measuring point solutions

Table of contents

Function and system design	3	Dimensions of the mounting clamp	18
Device selection	3	Dimensions of the extension cable mounting screws	19
Measuring principle	4	Dimensions of the IP66/IP67 terminal boxes with filters	19
Measuring system	5	Dimensions of the TMT182 temperature head transmitter	20
Level measurement with absolute pressure probe and external pressure signal	7	Terminal box with integrated TMT182 temperature head transmitter (4 to 20 mA/HART)	20
Density compensation with Pt100 temperature sensor	7	Weight	20
Communication protocol	8	Material	21
System integration	8	Extension cable	21
		Terminals	21
Input	9	Human interface	22
Measured variable	9	Field Xpert SFX100	22
Measuring range	9	Field Communicator 375, 475	22
Input signal	9	FieldCare	22
Output	10	Certificates and approvals	23
Output signal	10	CE mark	23
Signal range	10	Approvals, types of protection	23
Signal on alarm	10	Drinking water approval	
Load	10	(for FMX21 with outer diameter 22 mm (0.87 in))	23
Resolution	11	Marine certificate	23
Damping	11	Standards and guidelines applied	23
Power supply	11	Ordering information	24
Measuring unit electrical connection	11	FMX21	24
Supply voltage	13	FMX21 (continued)	25
Cable specifications	13	Accessories	26
Power consumption	13	Mounting clamp	26
Current consumption	13	Terminal box	26
Residual ripple	13	Additional weight	
Performance characteristics	14	(for FMX21 with outer diameter of 22 mm (0.87 in) or 29 mm (1.14 in))	26
Reference operating conditions	14	TMT182 temperature head transmitter (4 to 20 mA/HART)	26
Reference accuracy	14	Extension cable mounting screw	26
Long-term stability	14	Terminals	26
Influence of medium temperature	14	Cable shortening kit	26
Warm-up period	14	Installation tool –	
Step response time	14	indicating the customer-specific length on the cable	27
Installation	15	Testing adapter	
Installation instructions	15	(for FMX21 with outer diameter of 22 mm (0.87 in) and 29 mm (1.14 in))	27
Ambient conditions	16	Additional documentation	28
Ambient temperature range	16	Field of activities	28
Storage temperature range	16	Technical Information	28
Degree of protection	16	Operating Instructions	28
Electromagnetic compatibility (EMC)	16	Safety instructions	28
Overvoltage protection	16	Installation/	
Process conditions	17	Control Drawings	28
Medium temperature range	17	Drinking water approval	28
Medium temperature limits	17	Configuration data sheet	29
Mechanical construction	18	Level	29
Dimensions of the level probe	18	Pressure	30

Function and system design

Device selection

Waterpilot FMX21	 P01-FMX21xxx-16-xx-xx-xx-002	 P01-FMX21xx-16-xx-xx-xx-003	 P01-FMX21xxx-16-xx-xx-xx-004
Field of application	Hydrostatic level measurement in deep wells e.g. drinking water	Hydrostatic level measurement in wastewater	Hydrostatic level measurement in saltwater
	<p>Caution!</p> <p>The Waterpilot is not suitable for use in biogas plants since the gases can diffuse through the elastomers (seals, extension cable). For applications with biogas Endress+Hauser offers the level transmitter Deltapilot.</p>		
Process connection	<ul style="list-style-type: none"> – Mounting clamp – Extension cable mounting screw with G1 1/2 A or 1 1/2 NPT thread 		
Outer diameter	22 mm (0.87 in)	42 mm (1.65 in)	max. 29 mm (1.14 in)
Extension cable	<ul style="list-style-type: none"> – PE extension cable – PUR extension cable – FEP extension cable 		
Seals	<ul style="list-style-type: none"> – FKM Viton – EPDM ¹⁾ 	<ul style="list-style-type: none"> – FKM Viton 	<ul style="list-style-type: none"> – FKM Viton – EPDM ¹⁾
Measuring ranges	<ul style="list-style-type: none"> – Gauge pressure: from 0 to 0.1 bar to 0 to 20 bar (0 to 1.5 psi to 0 to 300 psi) – Absolute pressure: from 0 to 2 bar to 0 to 20 bar (0 to 30 psi to 0 to 300 psi) 		<ul style="list-style-type: none"> – Gauge pressure: from 0 to 0.1 bar to 0 to 4 bar (0 to 1.5 psi bis 0 to 60 psi) – Absolute pressure: from 0 to 2 bar to 0 to 4 bar (0 to 1.5 psi bis 0 to 60 psi)
	<ul style="list-style-type: none"> – Customer-specific measuring ranges; factory-calibrated – The following output units can be configured: %, mbar, bar, kPa, MPa, mmH₂O, mH₂O, inH₂O, ftH₂O, psi and numerous level units. 		
Overload	Up to 40 bar (580 psi)		Up to 25 bar (362 psi)
Process temperature range	–10 to +70 °C (+14 to +158 °F)		0 to +50 °C (+32 to +122 °F)
Reference accuracy	<ul style="list-style-type: none"> – ±0.2 % of the set span – Optional: ±0.1 % of set span (PLATINUM version) 		
Supply voltage	10.5 to 35 V DC, Ex: 10.5 to 30 V DC		
Output	4 to 20 mA (invertible) with superimposed digital communication protocol HART 6.0, 2-wire (invertible)		
Options	<ul style="list-style-type: none"> – Drinking water approval – Large selection of approvals, including ATEX, FM, CSA – Broad range of accessories – Integrated Pt100 temperature sensor and TMT182 temperature head transmitter (4 to 20 mA/HART) 		
Specialties	<ul style="list-style-type: none"> – High-precision, robust ceramic measuring cell with long-term stability – Automatic density compensation – Customer specific cable marking – Absolute pressure cell 		

1) Recommended for drinking water applications.

Measuring principle

The ceramic measuring cell is a dry measuring cell, i.e. pressure acts directly on the robust ceramic process isolating diaphragm of the Waterpilot FMX21.

Any changes in the air pressure are routed through the extension cable, via a pressure compensation tube, to the rear of the ceramic process isolating diaphragm and compensated for. A pressure-dependent change in capacitance caused by the movement of the process isolating diaphragm is measured at the electrodes of the ceramic carrier. The electronics then convert this into a signal which is proportional to the pressure and is linear to the level of the medium.

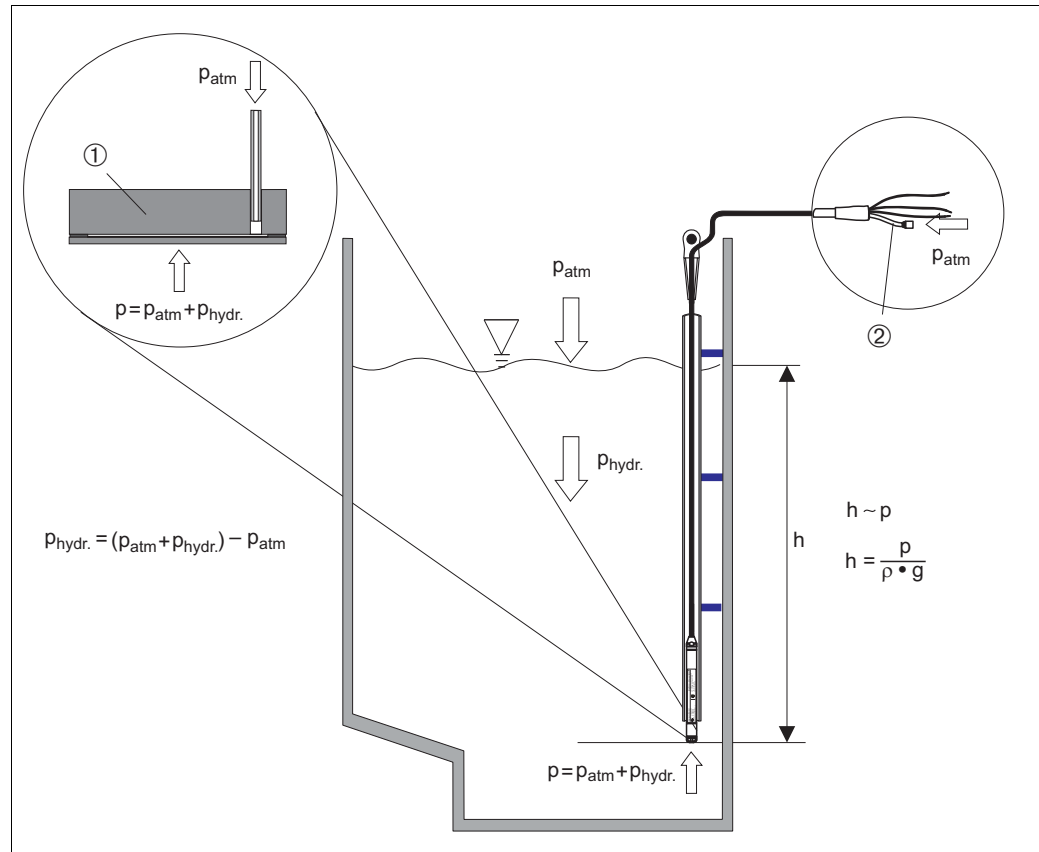

Measuring principle

- 1 Ceramic measuring cell
- 2 Pressure compensation tube
- h Level height
- p Total pressure = hydrostatic pressure + atmospheric pressure
- ρ Density of the medium
- g Gravitational acceleration
- $p_{hydr.}$ Hydrostatic pressure
- p_{atm} Atmospheric pressure

Temperature measurement with optional Pt100 ¹⁾

Endress+Hauser also offers the Waterpilot FMX21 with an optional 4-wire Pt100 resistance thermometer to measure level and temperature simultaneously. The Pt100 belongs to Accuracy Class B in accordance with DIN EN 60751, see also → 26 "Accessories".

Temperature measurement with optional Pt100 and TMT182 temperature head transmitter ¹⁾

Endress+Hauser also offers the TMT182 temperature head transmitter with the HART protocol to convert the temperature signal to an analog, scalable 4 to 20 mA output signal superimposed with HART 6.0, see also → 7 "Density compensation with Pt100 temperature sensor" → 24 "Ordering information" → 26 Chap. "Accessories" and Technical Information TI00078R.

1) Not for use in hazardous areas.

Measuring system

As standard, the complete measuring system consists of a Waterpilot FMX21 and a transmitter power supply unit with a supply voltage of 10.5 to 30 V DC (hazardous areas) or 10.5 to 35 V DC (non-hazardous areas).

Possible measuring point solutions with a transmitter and evaluation units from Endress+Hauser:

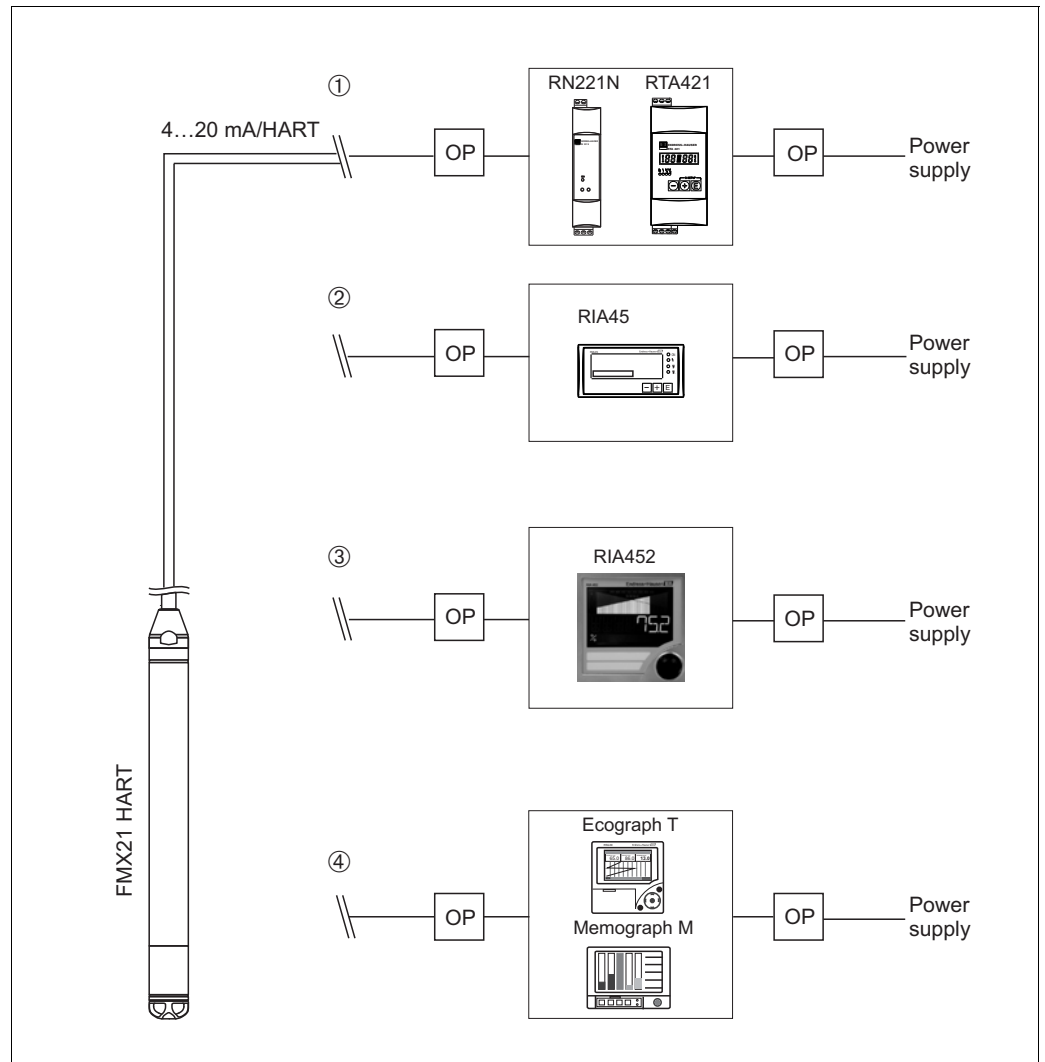
**Sample applications with FMX21**

OP = Overvoltage protection, e.g. HAW from Endress+Hauser (not for use in hazardous areas)

- OP on sensor side for field installation: HAW569/for top-hat/DIN rail: HAW562/intrinsically safe HAW562Z

- OP on power supply side for top-hat/DIN rail: HAW561 (115/230 V) and HAW561K (24/48 V AC/DC)

The overvoltage protection selected must be appropriate for the supply voltage.

1. Easy and cost-effective measuring point solution: power supplied to the Waterpilot in hazardous and non-hazardous areas via the RN221N active barrier. Power supply and additional control of two appliances, such as pumps, by means of the RTA421 limit value switch with onsite display.
2. The RIA45 units (for panel mounting) offer power supply, an onsite display, two switch outputs and signal adjustment (turndown).
3. If several pumps are used, the pump service life can be prolonged by alternate switching. With alternating pump control, the pump which was out of service for the longest period of time is switched on. The evaluation unit RIA452 (for panel mounting) provide this option in addition to several other functions.
4. State-of-the-art recording technology with graphic display recorders from Endress+Hauser, such as Ecograph T, Memograph M for documenting, monitoring, visualizing and archiving purposes.

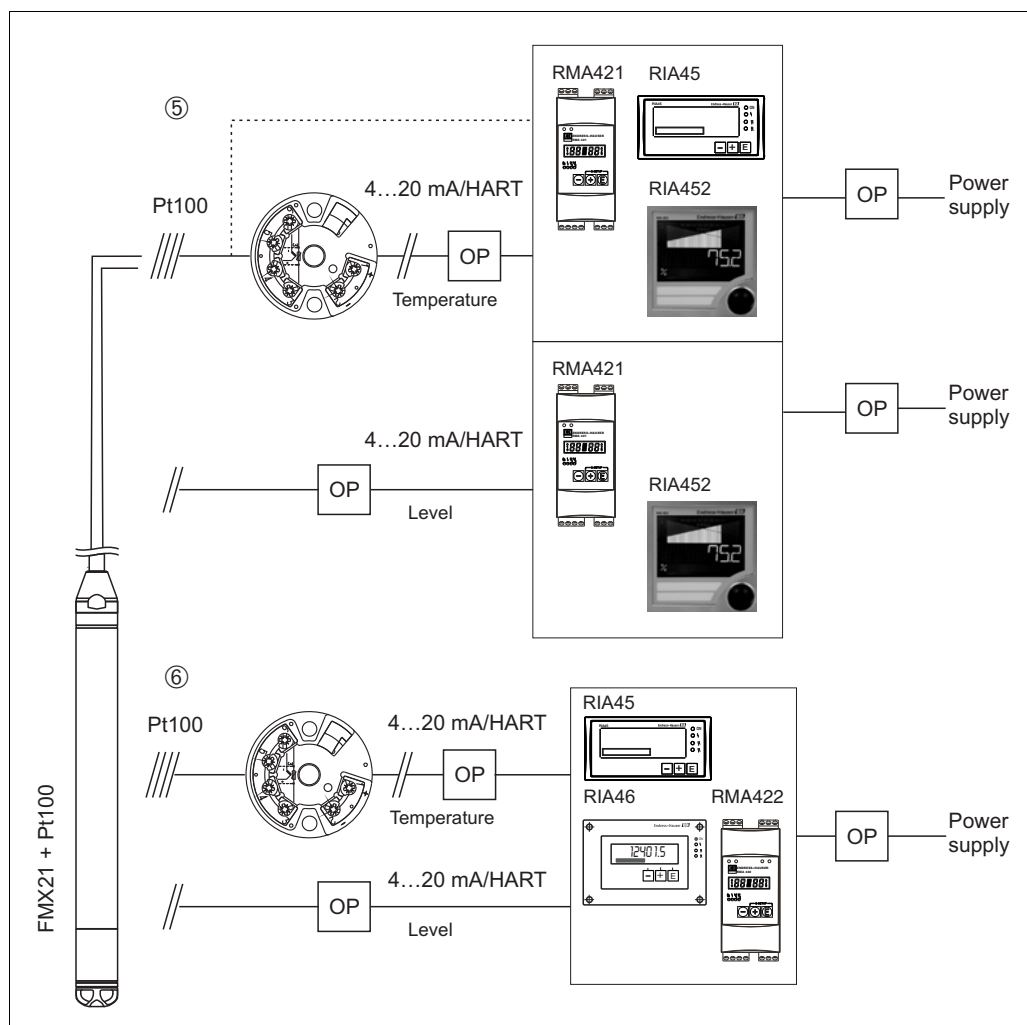

P01-FMX21xx-14-xx-xx-et-005

Sample applications with FMX21 with Pt100

OP = Overvoltage protection e.g. HAW from Endress+Hauser (not for use in hazardous areas)

- OP on sensor side for field installation: HAW569/for top-hat/DIN rail: HAW562/intrinsically safe HAW562Z

- OP on power supply side for top-hat/DIN rail: HAW561 (115/230 V) and HAW561K (24/48 V AC/DC)

The overvoltage protection selected must be appropriate for the supply voltage.

5. If you want to measure, display and evaluate the temperature as well as the level, e.g. to monitor temperature in fresh water to detect temperature limits for germ formation, you have the following options:
The optional TMT182 temperature head transmitter can convert the Pt100 signal to a 4 to 20 mA HART signal and transfer it to any common evaluation unit. The RMA421, RIA45 and RIA452 evaluation units also offer a direct input for the Pt100 signal.
6. If you want to record and evaluate the level and temperature measured value with one device, use the RMA422, RIA45 and RIA46 evaluation unit with two inputs. It is even possible to mathematically link the input signals with this unit. These evaluation are not HART permeable.

Level measurement with absolute pressure probe and external pressure signal

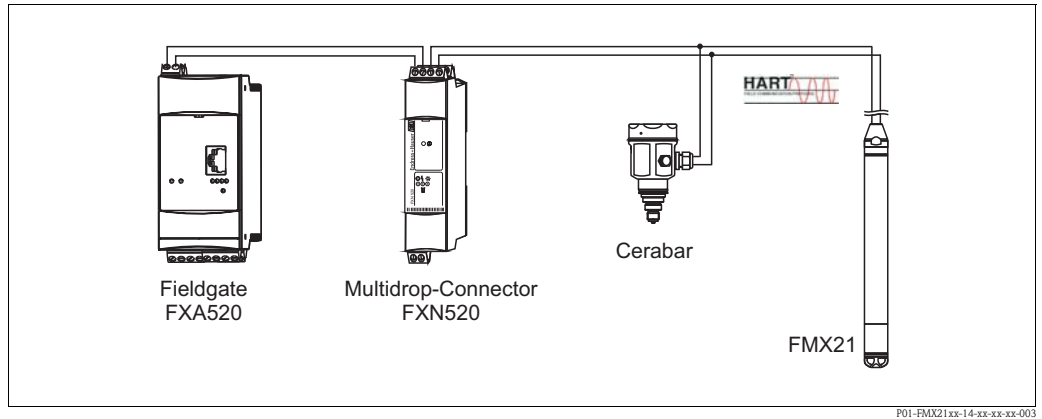

It is advisable to use an absolute pressure probe for applications in which condensation can occur. In the case of level measurement with an absolute pressure probe, the measured value is affected by fluctuations in the ambient air pressure. To correct the resulting measured error, you can connect an external absolute pressure sensor (e.g. Cerabar) to the HART signal cable, switch the waterpilot to the burst mode and the Cerabar to operate in mode "Electr. Delta P".

The external absolute pressure sensor then calculates the difference between the two pressure signals and can thus determine the level precisely. Only one level measured value can be corrected in this way.

Caution!

If using intrinsically safe devices, strict compliance with the rules for interconnecting intrinsically safe circuits as stipulated in IEC60079-14 (proof of intrinsic safety) is mandatory.

Density compensation with Pt100 temperature sensor

The Waterpilot FMX21 can correct measured errors that result from fluctuations in the density of the water caused by temperature. Users can choose from the following options:

Use the internally measured sensor temperature of the FMX21

The internally measured sensor temperature is calculated in the Waterpilot FMX21 for density compensation. The level signal is thus corrected according to the density characteristic line of the water.

Use the optional internal temperature sensor for density compensation in a suitable HART master (e.g. PLC)

The Waterpilot FMX21 is available with an optional Pt100 temperature sensor. Endress+Hauser additionally offers the TMT182 temperature head transmitter to convert the Pt100 signal to a 4 to 20 mA HART signal. The temperature and pressure signal is transmitted to the HART master (e.g. PLC) where a corrected level value can be generated using a stored linearization table or the density function (of a chosen medium).

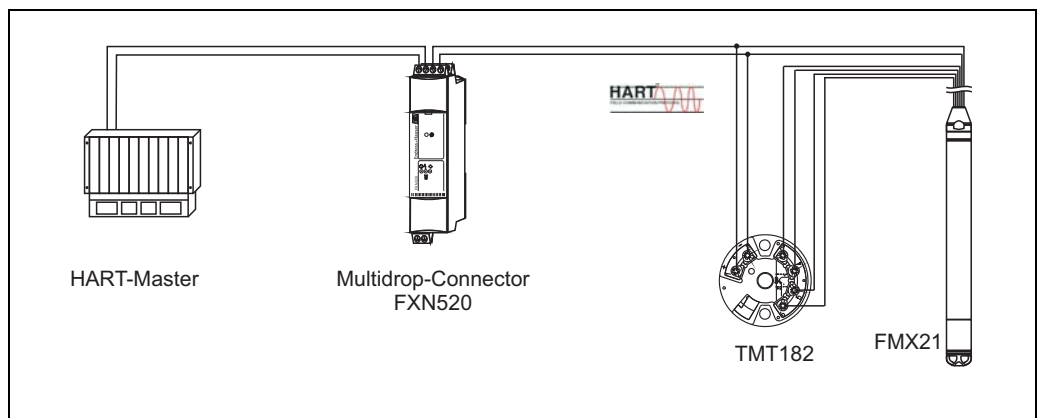

Use an external temperature signal which is transmitted to the FMX21 via HART burst mode

The Waterpilot FMX21 is available with an optional Pt100 temperature sensor. In this case, the signal of the Pt100 is analyzed using a HART-compliant (at least HART 5.0) temperature transmitter that supports BURST mode. The temperature signal can thus be transmitted to the FMX21. The FMX21 uses this signal for the density correction of the level signal.

Note!

The TMT182 temperature head transmitter is not suitable for this configuration.

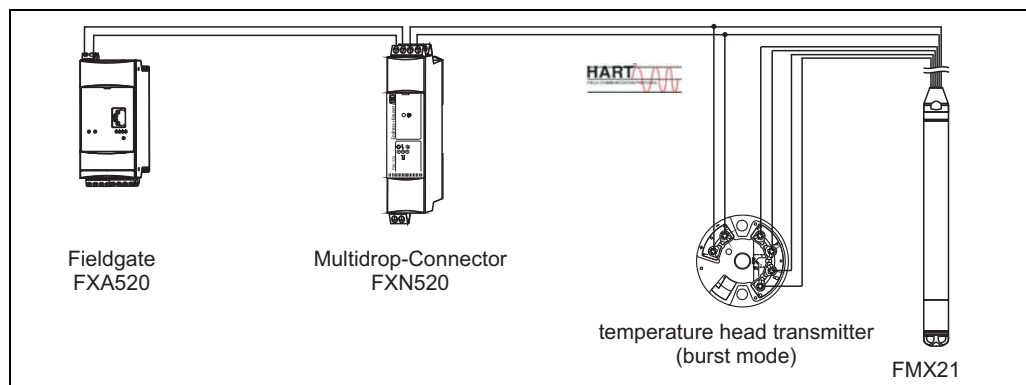

Without compensation additional errors of up to 4 % can occur at a temperature of 70 °C (158 °F) for example. With density compensation, this error can be decreased to 0.5% in the entire temperature range from 0 to 70 °C (32 to 158 °F).

Note!

For further information on the devices, please refer to the appropriate Technical Information:

- TI00078R: TMT182 temperature head transmitter (4 to 20 mA/HART)
- TI00369F: FXA520 Fieldgate
- TI00400F: FXN520 multidrop connector

Communication protocol 4 to 20 mA HART with communication protocol

System integration The device can be fitted with a tag name, see → 24 ff "Ordering information", feature 895 "Marking" version "Z1".

Input

Measured variable	FMX21 + Pt100 (optional)	TMT182 temperature head transmitter (optional)
	<ul style="list-style-type: none"> ■ Hydrostatic pressure of a liquid ■ Pt100: temperature 	

Measuring range

- Customer-specific measuring ranges; factory-calibrated
- Temperature measurement from -10 to +70 °C (+14 to +158 °F) with Pt100 (optional)
- A sensor measuring range turndown (TD) of up to 10:1 can be set at the factory or directly by the customer.

Sensor measuring range	Smallest span that can be calibrated	Maximum overload/OPL ¹⁾	Vacuum resistance	Version in the order code ²⁾
[bar (psi)]	[bar (psi)]	[bar (psi)]	[bar _{abs} (psi _{abs})]	
Gauge pressure				
0.1 (1.5)	0.01 (0.15)	5.0 (75.0)	0.3 (4.5)	1C
0.2 (3.0)	0.02 (0.3)	5.0 (75.0)	0.3 (4.5)	1D
0.4 (6.0)	0.04 (1.0)	6.0 (90.0)	0	1F
0.6 (9.0)	0.06 (1.0)	10.0 (150)	0	1G
1.0 (15.0)	0.1 (1.5)	10.0 (150)	0	1H
2.0 (30.0)	0.2 (3.0)	15.0 (225)	0	1K
4.0 (60.0)	0.4 (6.0)	25.0 (375)	0	1M
10.0 (150) ³⁾	1.0 (15)	40.0 (600)	0	1P
20.0 (300) ³⁾	2.0 (30)	40.0 (600)	0	1Q
Absolute pressure				
2.0 (30.0)	0.2 (3.0)	15.0 (225)	0	2K
4.0 (60.0)	0.4 (6.0)	25.0 (375)	0	2M
10.0 (150) ³⁾	1.0 (15)	40.0 (600)	0	2P
20.0 (300) ³⁾	2.0 (30)	40.0 (600)	0	2Q

1) OPL: overpressure limit, depending on the weakest element, in terms of pressure, of the selected components

2) See → 24 "Ordering information"

3) These measuring ranges are not offered for the probe version with a coated housing, outer diameter 29 mm (1.14 in).

Input signal	FMX21 + Pt100 (optional)	TMT182 temperature head transmitter (optional)
	<ul style="list-style-type: none"> ■ Change in capacitance ■ Pt100: change in resistance 	

Output

Output signal	FMX21 + Pt100 (optional)	TMT182 temperature head transmitter (optional)
	<ul style="list-style-type: none"> 4 to 20 mA with overlying digital HART 6.0 communication protocol, 2-wire for hydrostatic pressure measured value Pt100: Temperature-dependent resistance values 	4 to 20 mA with overlying digital HART 5.0 communication protocol for temperature measured value, 2-wire

Signal range ■ 3.8 to 20.5 mA

Signal on alarm	FMX21 + Pt100 (optional)	TMT182 temperature head transmitter (optional)
	<p>4 to 20 mA/HART</p> <p>Options:</p> <ul style="list-style-type: none"> Max. alarm (factory setting 22mA): can be set from 21 to 23 mA Hold measured value: last measured value is held Min. alarm: 3.6 mA 	<p>Options:</p> <ul style="list-style-type: none"> Max. alarm ≥ 21.0 mA Min. alarm ≤ 3.6 mA

Load	FMX21	TMT182 temperature head transmitter (optional)
	$R_{Lmax} \leq \frac{U - 10.5 \text{ V}}{23 \text{ mA}} - 2 \cdot 0.9 \frac{\Omega}{\text{m}} \cdot l - R_{add}$ <p style="text-align: right; font-size: small;">P01-FMX21xx-16-xx-xx-en-000</p>	$R_{tot} \leq \frac{U - 11.5 \text{ V}}{0.023 \text{ A}} - R_{add}$ <p style="text-align: right; font-size: small;">P01-FMX21xx-16-xx-xx-en-001</p>

R_{Lmax} = Max. load resistance [Ω]

R_{add} = Additional resistances such as resistance of evaluation unit and/or display unit, cable resistance [Ω]

U = Supply voltage [V]

l = Simple length of extension cable [m] (cable resistance per wire $\leq 0.09 \Omega/\text{m}$)

Note!

When using the measuring device in hazardous areas, installation must comply with the applicable national standards and regulations and the Safety Instructions or Installation or Control Drawings.

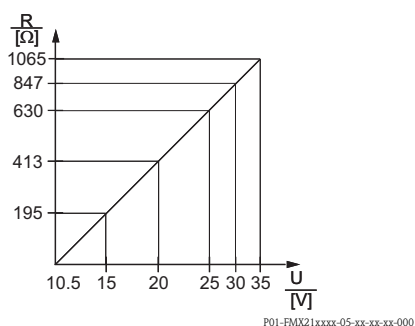

FMX21 load chart for estimating the load resistance. Additional resistances, such as the resistance of the extension cable, have to be subtracted from the value calculated as shown in the equation.

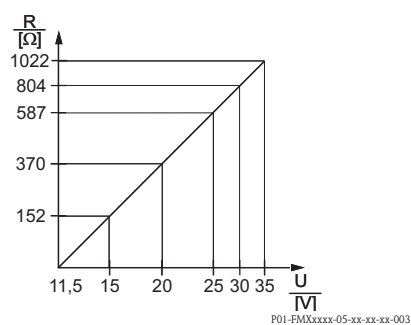

Temperature head transmitter load chart for estimating the load resistance. Additional resistances have to be subtracted from the value calculated as shown in the equation.

Note!

When operating using a HART handheld terminal or a PC with an operating program, a minimum communication resistance of 250 Ω has to be taken into account.

Resolution

Current output: 1 μ A

Read cycle

HART commands: 2 to 3 per second on average

Damping

- Continuously 0 to 999 s via HART handheld terminal or PC with operating program
- Factory setting: 2 s

Power supply

Measuring unit electrical connection

Note!

- When using the measuring device in hazardous areas, installation must comply with the applicable national standards and regulations and the Safety Instructions (XAs) and the Installation or Control Drawings (ZDs). → 28 "Additional documentation", "Safety instructions" and "Installation/Control Drawings".
- Reverse polarity protection is integrated in the Waterpilot FMX21 and in the TMT182 temperature head transmitter. Changing the polarities will not damage the devices.
- The cable must end in a dry room or a suitable terminal box. The terminal box (IP66/IP67) with a GORE-TEX® filter from Endress+Hauser is suitable for outdoor installations. The terminal box can be ordered as an accessory using the order code for FMX21 → 24 version "PS" for feature 620.

The electrical connection is made with the corresponding wires of the probe cable and with the optional use of the terminal box (Commubox FXA) or an active barrier (e.g. RN221N).

FMX21

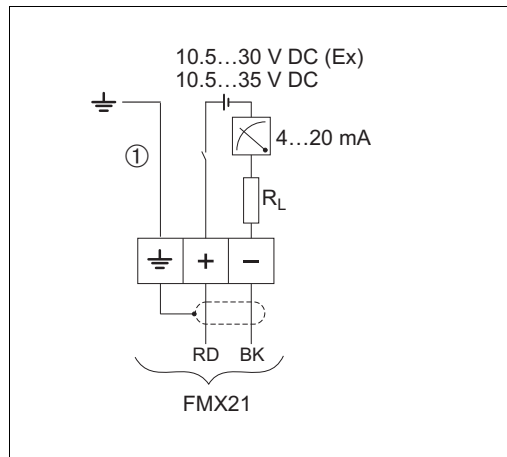

Electrical connection

FMX21 with Pt100¹⁾

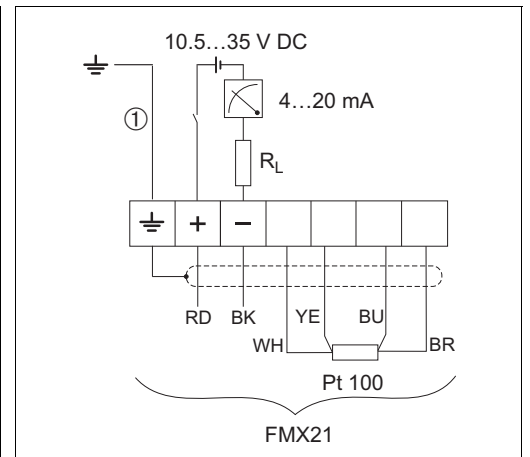

Electrical connection

Version "NB" for feature 610 "Accessories" in the order code → 24 ff.

① Not for FMX21 with an outer diameter of 29 mm (1.14 in).

¹⁾ Not for use in hazardous areas.

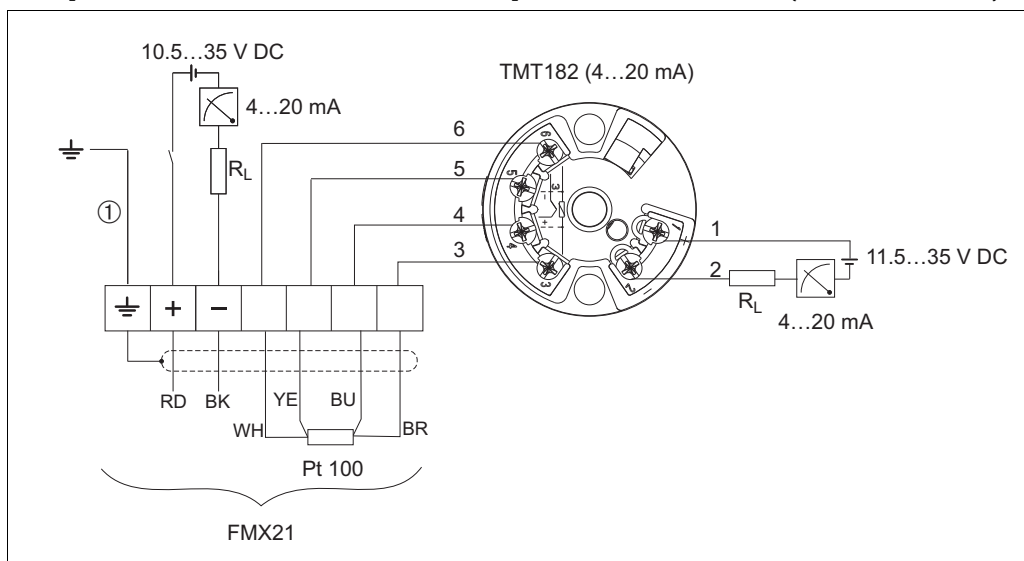
Waterpilot FMX21 with Pt100 and TMT182 temperature head transmitter (4 to 20 mA/HART) ¹⁾

P01-FMX21xxx-04-xx-xx-xx-007

FMX21 with Pt100 and TMT182 temperature head transmitter
versions "NB" and "PT" for the features 610 and 620 in the order code → 24 ff.

① Not for FMX21 with an outer diameter of 29 mm (1.14 in).

Wire colors: RD = red, BK = black, WH = white, YE = yellow, BU = blue, BR = brown

¹⁾ Not for use in hazardous areas.

Connection classification as per IEC 61010-1:

- Overvoltage category 1
- Pollution degree 1

Connection data in the hazardous area

4 to 20 mA	Ex ia IIC T4 to T6
U _i	30 V DC
I _i	133 mA
P _i	1.0 W
C _i	10.3 nF (sensor)/180 pF/m (cable)
L _i	0 μH (sensor)/1 μH/m (cable)
T _a	-10 °C (+14 °F) ≤ T _a ≤ +70 °C (+158 °F) for T4; -10 °C (+14 °F) ≤ T _a ≤ +40 °C (+104 °F) for T6

Supply voltage	<p>Note!</p> <ul style="list-style-type: none"> When using the measuring device in hazardous areas, installation must comply with the applicable national standards and regulations and the Safety Instructions (XAs) and the Installation or Control Drawings (ZDs). All explosion-protection data are given in a separate documentation which is available upon request. This documentation is provided with the devices as standard, see also → 28 "Additional documentation". <p>FMX21 + Pt100 (optional)</p> <ul style="list-style-type: none"> 10.5 to 35 V (non-hazardous area) 10.5 to 30 V (hazardous area) 	<p>TMT182 temperature head transmitter (optional)</p> <p>11.5 to 35 V DC</p>
Cable specifications	<p>FMX21 + Pt100 (optional)</p> <ul style="list-style-type: none"> Commercially available shielded instrument cable Terminal, terminal box: 0.08 to 2.5 mm² (28 to 14 AWG) If the Pt100 signal is directly connected to a display and/or evaluation unit, Endress+Hauser recommends using a shielded cable. 	<p>TMT182 temperature head transmitter (optional)</p> <ul style="list-style-type: none"> Commercially available shielded instrument cable Terminal, terminal box: 0.08 to 2.5 mm² (28 to 14 AWG) Transmitter connection: max. 1.75 mm² (15 AWG)
Power consumption	<p>FMX21 + Pt100 (optional)</p> <ul style="list-style-type: none"> ≤ 0.805 W at 35 V DC (non-hazardous area) ≤ 0.690 W at 30 V DC (hazardous area) 	<p>TMT182 temperature head transmitter (optional)</p> <p>≤ 0.805 W at 35 V DC</p>
Current consumption	<p>FMX21 + Pt100 (optional)</p> <ul style="list-style-type: none"> Max. current consumption: ≤ 23 mA Min. current consumption: ≥ 3.6 mA Pt100: ≤ 0.6 mA 	<p>TMT182 temperature head transmitter (optional)</p> <ul style="list-style-type: none"> Max. current consumption: ≤ 23 mA Min. current consumption: ≥ 3.5 mA Pt100 via temperature head transmitter: ≤ 0.6 mA
Residual ripple	<p>FMX21 + Pt100 (optional)</p> <p>No impact on 4 to 20 mA signal to ±5 % residual ripple within the permitted voltage range (according to HART Hardware Specification HCF_SPEC-54 (DIN IEC 60381-1)).</p>	<p>TMT182 temperature head transmitter (optional)</p> <p>$U_{ss} \geq 3 \text{ V}$ at $U_b \geq 13 \text{ V}$, $f_{max} = 1 \text{ kHz}$</p>

Performance characteristics

Reference operating conditions	FMX21 + Pt100 (optional) <ul style="list-style-type: none"> ■ As per IEC 60770 ■ Ambient temperature T_A = constant, in range: +21 to +33 °C (+70 °F to +91 °F) ■ Humidity φ = constant, in range: 20 to 80 % RH ■ Ambient pressure p_A = constant, in range: 860 to 1060 mbar (12.47 to 15.37 psi) ■ Position of the measuring cell = constant, in range: vertical: $\pm 1^\circ$ ■ Supply voltage constant: 21 V DC to 27 V DC ■ Load with HART: 250 Ω ■ Pt100: DIN EN 60770 $T_A = 25\text{ °C}$ (77 °F) 	TMT182 temperature head transmitter (optional) Calibration temperature 25 °C (77 °F) $\pm 5\text{ K}$
Reference accuracy	FMX21 + Pt100 (optional) The reference accuracy comprises the non-linearity after limit point configuration, hysteresis and non-repeatability in accordance with IEC 60770. <ul style="list-style-type: none"> ■ Setting $\pm 0.2\%$ <ul style="list-style-type: none"> – to TD 5:1: $< 0.2\%$ of the set span – from TD 5:1 to TD 10:1 $\pm(0.02 \times \text{TD} + 0.1)$ PLATINUM version: ■ Setting $\pm 0.1\%$ (optional) <ul style="list-style-type: none"> – to TD 5:1: $< 0.1\%$ of the set span – from TD 5:1 to TD 10:1 $\pm(0.02 \times \text{TD})$ ■ Class B to DIN EN 60751 <ul style="list-style-type: none"> – Pt100: max. $\pm 1\text{ K}$ 	TMT182 temperature head transmitter (optional) <ul style="list-style-type: none"> ■ $\pm 0.2\text{ K}$ ■ With Pt100: max. $\pm 0.9\text{ K}$
Long-term stability	FMX21 + Pt100 (optional) <ul style="list-style-type: none"> ■ $\leq 0.1\%$ of URL/year ■ $\leq 0.25\%$ of URL/5 years 	TMT182 temperature head transmitter (optional) $\leq 0.1\text{ K}$ per year
Influence of medium temperature	<ul style="list-style-type: none"> ■ Thermal change in the zero output and the output span 0 to +30 °C (+32 to +86 °F): $<(0.15 + 0.15 \times \text{TD})\%$ -10 to +70 °C (+14 to +158 °F): $<(0.4 + 0.4 \times \text{TD})\%$ ■ Temperature coefficient (T_K) of the zero output and output span -10 to +70 °C (+14 to +158 °F): 0.1 % / 10 K URL 	
Warm-up period	FMX21 + Pt100 (optional) FMX21: $< 6\text{ s}$ Pt100: 20 ms	TMT182 temperature head transmitter (optional) 4 s
Step response time	FMX21 + Pt100 (optional) <ul style="list-style-type: none"> ■ FMX21: 400 ms (T90 time), 500 ms (T99 time) ■ Pt100: 160 s (T90 time), 300 s (T99 time) 	–

Installation

Installation instructions

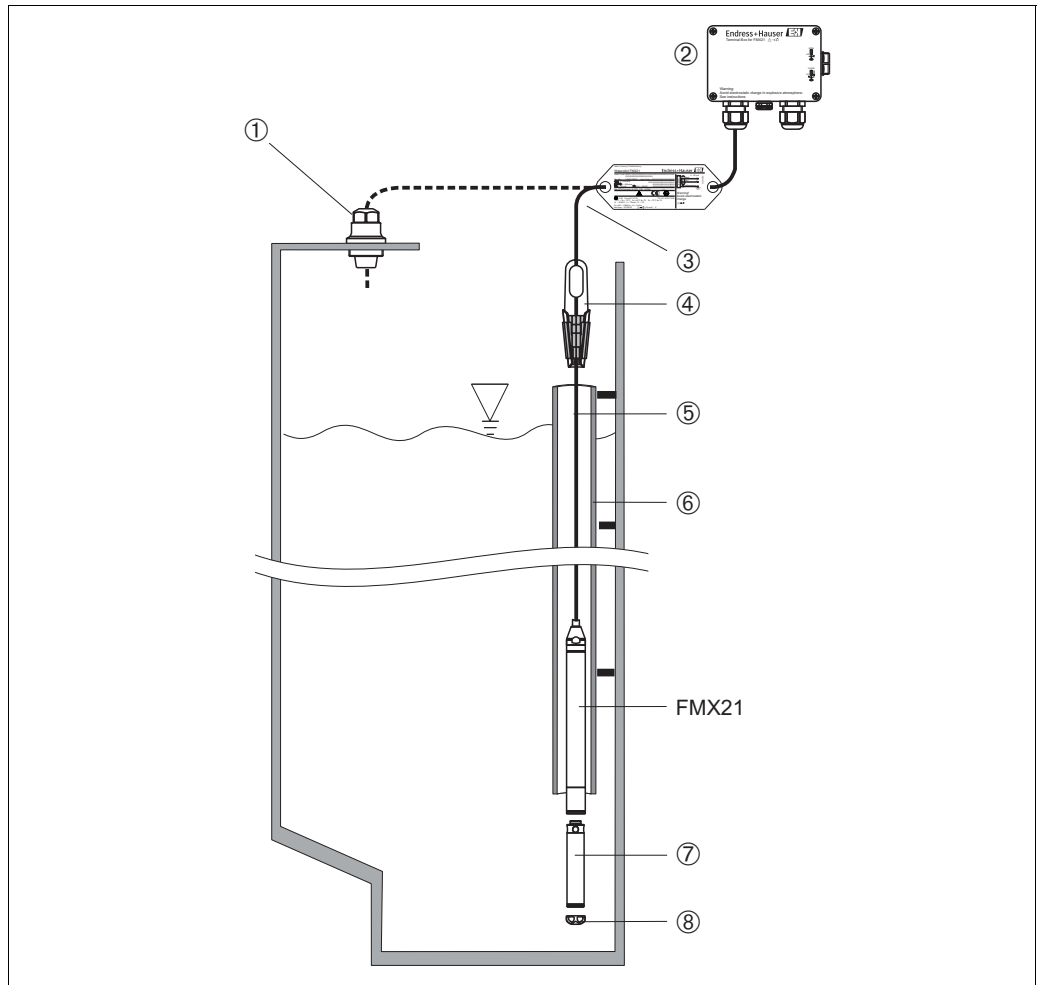

P01-FMX21xx-11-xxx-xx-xx-003

Installation examples, here illustrated with FMX21 with an outer diameter of 22 mm (0.87 in)

- 1 Extension cable mounting screw can be ordered via order code or as an accessory → 24 ff
- 2 Terminal box can be ordered via order code or as an accessory → 24 ff
- 3 Extension cable bending radius > 120 mm (4.72 in)
- 4 Mounting clamp can be ordered via order code or as an accessory → 24 ff
- 5 Extension cable, length → 21
- 6 Guide pipe
- 7 Additional weight can be ordered as an accessory for FMX21 with an outer diameter of 22 mm (0.87 in) and 29 mm (1.14 in) → 26
- 8 Protection cap

Note!

- Sideways movement of the level probe can result in measuring errors. For this reason, install the probe at a point free from flow and turbulence, or use a guide tube. The internal diameter of the guide tube should be at least 1 mm (0.04 in) bigger than the outer diameter of the selected FMX21.
- The cable must end in a dry room or a suitable terminal box. The terminal box from Endress+Hauser provides optimum humidity and climatic protection and is suitable for outdoor installation.
- Protection cap: The device is provided with a protection cap to prevent mechanical damage to the measuring cell. This cap should not be removed during the transportation and installation process.
- If the cable is shortened, the filter at the pressure compensation tube has to be reattached. Endress+Hauser offers a cable shortening kit for this purpose → 24 ff (SD00552P/00/A6).
- Endress+Hauser recommends using twisted, shielded cables.
- Note for ship building applications: Measures for limitation of the propagation of fire along cable bundles are required (fire stops).

Ambient conditions

Ambient temperature range	<p>FMX21 + Pt100 (optional)</p> <ul style="list-style-type: none"> ■ FMX21 with outer diameter of 22 mm (0.87 in) and 42 mm (1.65 in): -10 to +70 °C (+14 to +158 °F) (= medium temperature) ■ FMX21 with outer diameter of 29 mm (1.14 in): 0 to +50 °C (+32 to +122 °F) (= medium temperature) <p>Terminal box</p> <p>-40 to +80 °C (-40 to +176 °F)</p>	<p>TMT182 temperature head transmitter (optional)</p> <p>-40 to +85 °C (-40 to +185 °F)</p>
Storage temperature range	<p>FMX21 + Pt100 (optional)</p> <p>-40 to +80 °C (-40 to +176 °F)</p> <p>Terminal box</p> <p>-40 to +80 °C (-40 to +176 °F)</p>	<p>TMT182 temperature head transmitter (optional)</p> <p>-40 to +100 °C (-40 to +212 °F)</p>
Degree of protection	<p>FMX21 + Pt100 (optional)</p> <p>IP68, permanently hermetically sealed at 40 bar (580 psi)(~400 m H₂O)</p> <p>Terminal box (optional)</p> <p>IP66/IP67</p>	<p>TMT182 temperature head transmitter (optional)</p> <p>IP00, condensation permitted</p>
Electromagnetic compatibility (EMC)	<p>FMX21 + Pt100 (optional)</p> <ul style="list-style-type: none"> ■ EMC in accordance with all the relevant requirements of the EN 61326 series. Details are provided in the Declaration of Conformity. ■ Maximum deviation <0.5 % of the span. 	<p>TMT182 temperature head transmitter (optional)</p> <p>EMC in accordance with all the relevant requirements of the EN 61326 series. Details are provided in the Declaration of Conformity.</p>
Overvoltage protection	<p>FMX21 + Pt100 (optional)</p> <p>Integrated overvoltage protection to EN 61000-4-5 (500 V symmetrical/1000 asymmetrical) Install overvoltage protection ≥1.0 kV, external if necessary</p>	<p>TMT182 temperature head transmitter (optional)</p> <p>Install overvoltage protection, external if necessary.</p>

Process conditions

Medium temperature range	FMX21 + Pt100 (optional) <ul style="list-style-type: none"> ■ FMX21 with outer diameter of 22 mm (0.87 in) and 42 mm (1.65 in): -10 to +70 °C (+14 to +158 °F) ■ FMX21 with outer diameter of 29 mm (1.14 in): 0 to +50 °C (+32 to +122 °F) 	TMT182 temperature head transmitter (optional)
		-
Medium temperature limits	FMX21 + Pt100 (optional) <ul style="list-style-type: none"> ■ FMX21 with outer diameter of 22 mm (0.87 in) and 42 mm (1.65 in): -20 to +70 °C (-4 to +158 °F) <p>Note! In hazardous areas incl. CSA GP, the medium temperature limit is at -10 to +70 °C (+14 to +158 °F).</p> <ul style="list-style-type: none"> ■ FMX21 with outer diameter of 29 mm (1.14 in): 0 to +50 °C (+32 to +122 °F) <p>(The FMX21 can be operated in this temperature range. The specification can then be exceeded, e.g. measuring accuracy.)</p>	
		-

Mechanical construction

Dimensions of the level probe

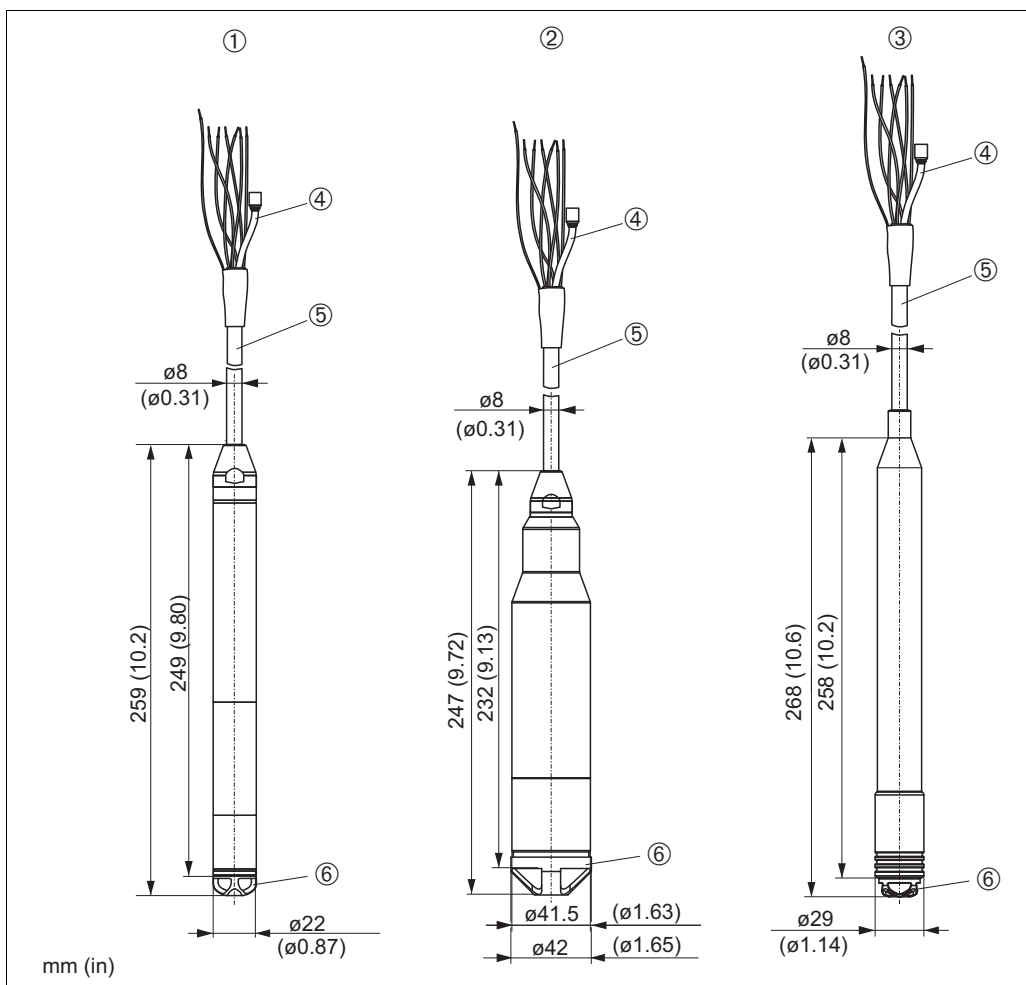

P01-FMX21xx-06-xx-xx-xx-008

Versions of the FMX21

- 1 Version "1" for feature 45 "Probe tube" or "Accessories" in the order code → 24 ff
- 2 Version "2" for feature 45 "Probe tube" in the order code → 24 ff
- 3 Version "5" for feature 45 "Probe tube" in the order code → 24 ff
- 4 Pressure compensation tube
- 5 Extension cable
- 6 Protection cap

Dimensions of the mounting clamp

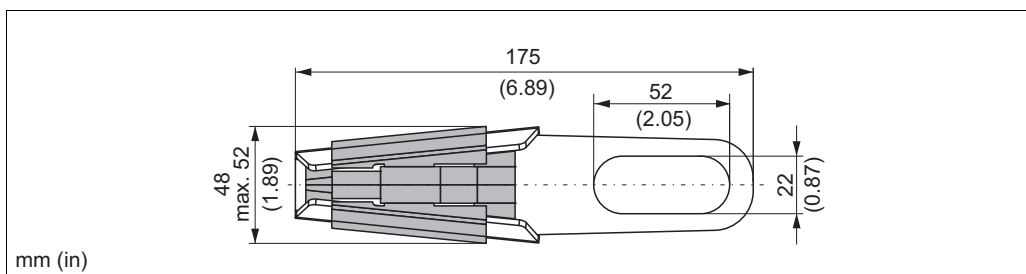

P01-FMXxxx-06-xx-xx-xx-010

Mounting clamp, version "PO" for feature 620 "Accessories" in the order code → 24 ff

Dimensions of the extension cable mounting screws

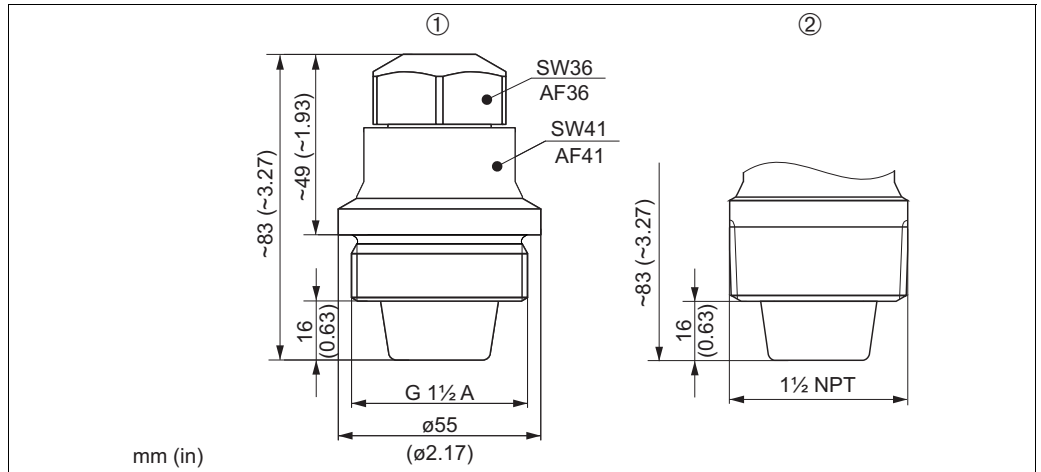

Extension cable mounting screws

- 1 Extension cable mounting screw G 1 1/2 A, version "PQ" for feature 620 "Accessories" in the order code → 24 ff
- 2 Extension cable mounting screw 1 1/2 NPT, version "PR" for feature 620 "Accessories" in the order code → 24 ff

Note!
Application in unpressurized containers only.

Dimensions of the IP66/IP67 terminal boxes with filters

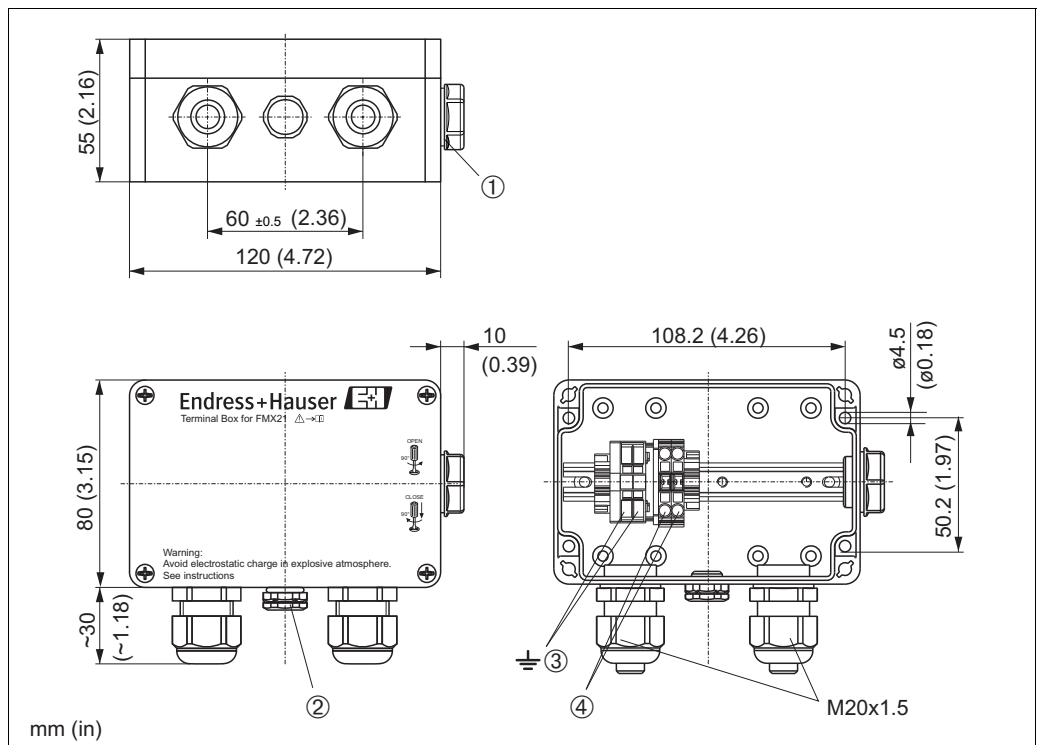

Terminal box / Version "PS" or "PT" for feature 620 "Accessories" in the order code → 24 ff

- 1 Dummy plug M20x1.5
- 2 GORE-TEX® filter
- 3 Ground connection / terminals for 0.08 to 2.5 mm² (28 to 14 AWG)
- 4 4 to 20 mA / terminals for 0.08 to 2.5 mm² (28 to 14 AWG)

If ordered together with FMX21 but without the optional TMT182 temperatur transmitter, the terminal box is incl. a 4-terminal strip.

Note!
The 4-terminal strip is not intended for use in hazardous areas incl. CSA GP.

Dimensions of the TMT182 temperature head transmitter

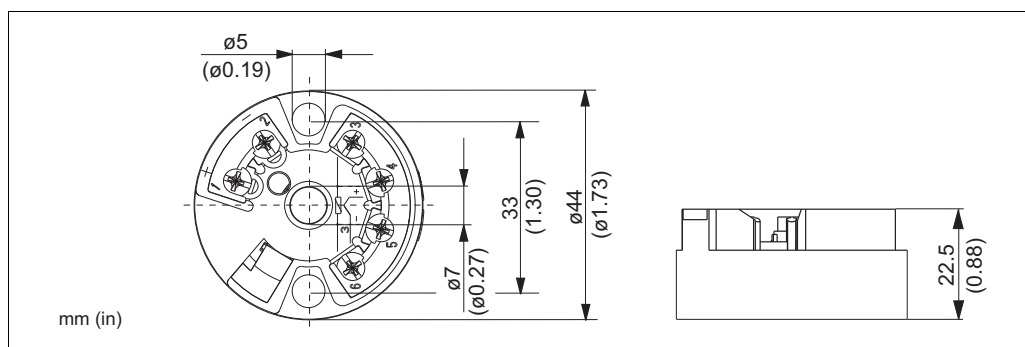

P01-FMX21xxx-06-xx-xx-012

TMT182 temperature head transmitter (4 to 20 mA/HART), version "PT" for feature 620 "Accessories" in the order code
→ 24 ff.

Terminal box with integrated TMT182 temperature head transmitter (4 to 20 mA/HART)

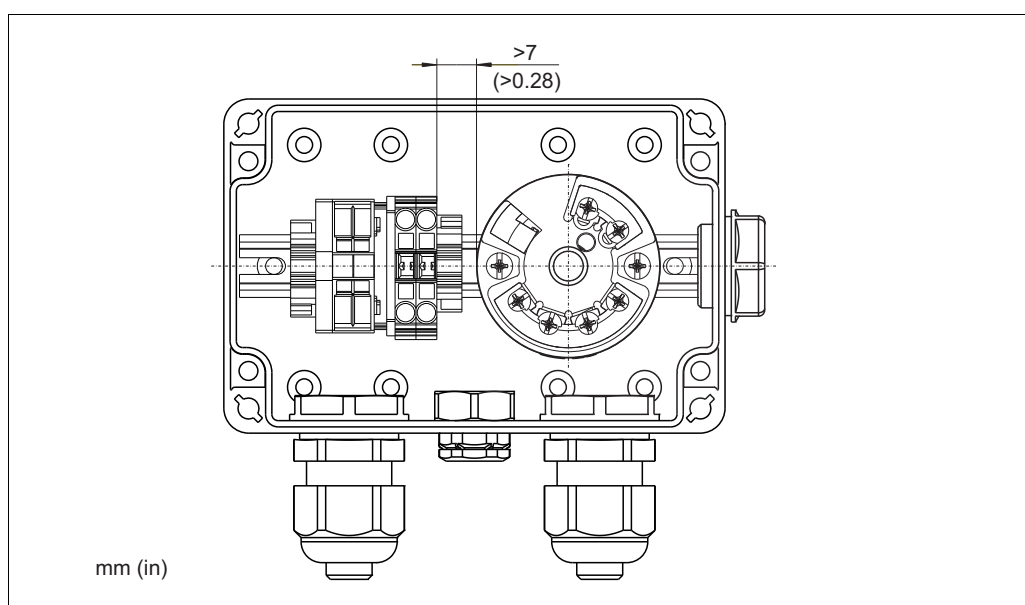

P01-FMX21xxx-06-xx-xx-022

Note!

A distance of >7 mm (>0.28 in mm) must be maintained between the terminal strip and the TMT182 temperature head transmitter.

Weight

- Level probe, outer diameter 22 mm (0.87 in): 344 g (12.133 oz)
- Level probe, outer diameter 29 mm (1.14 in): 394 g (13.896 oz)
- Level probe, outer diameter 42 mm (1.65 in): 1376 g (48.532 oz)
- PE extension cable: 52 g/m (0.33 lbs/1 ft)
- FEP extension cable: 108 g/m (0.072 lbs/1 ft)
- PUR extension cable: 60 g/m (0.039 lbs/1 ft)
- Mounting clamp: 170 g (5.996 oz)
- Extension cable mounting screw G1 ½ A: 770 g (27.158 oz)
- Extension cable mounting screw 1 ½ NPT: 724 g (25.535 oz)
- Terminal box: 235 g (8.288 oz)
- Temperature head transmitter: 40 g (1.411 oz)
- Additional weight: 300 g (1.376 oz)
- Adapter weight: 39 g

Material

- Level probe, outer diameter 22 mm (0.87 in): 1.4435 (AISI 316L)
- Level probe, outer diameter 29 mm (1.14 in): 1.4435 (AISI 316L)
 - Sensor sleeve: PPS (polyphenylene sulfide); heat-shrink tube/cover: polyolefin.
 - The materials used ensure that metal does not come in contact with the medium.
- Level probe, outer diameter 42 mm (1.65 in): 1.4435 (AISI 316L)
- Process ceramic: Al₂O₃ aluminum oxide ceramic
- Seal (internal): EPDM or Viton
- Protection cap: – PPO (polyphenylene oxide) for FMX21 with outer diameter 22 mm and 29 mm.
 - PFA (perfluoroalkoxy) for FMX21 with outer diameter 42 mm.
- Extension cable insulation: either PE-LD (low-density polyethylene), FEP (fluorinated ethylene propylene) or PUR (polyurethane), for further information, see → 21 "Extension cable".
- Mounting clamp: 1.4404 (AISI 316L) and fiberglass reinforced PA (polyamide)
- Extension cable mounting screw G1 ½ A: 1.4301 (AISI 304)
- Extension cable mounting screw 1 ½ NPT: 1.4301 (AISI 304)
- Terminal box: PC (polycarbonate)
- Temperature head transmitter: PC housing (polycarbonate)

Extension cable**PE extension cable**

- Abrasion-resistant extension cable with Dynema strain-relief members; shielded with aluminum-coated film; insulated with polyethylene (PE), black; copper wires, twisted
- Pressure compensation tube with Teflon filter

PUR extension cable

- Abrasion-resistant extension cable with Dynema strain-relief members; shielded with aluminum-coated film; insulated with polyurethane (PUR), black; copper wires, twisted
- Pressure compensation tube with Teflon filter

FEP extension cable

- Abrasion-resistant extension cable; shielded with galvanized steel wire netting; insulated with fluorinated ethylene propylene (FEP), black; copper wires, twisted
- Pressure compensation tube with Teflon filter

Cross-section of PE/PUR/FEP extension cable

- Total outer diameter: 8.0 mm (0.31 in) ±0.25 mm (±0.01 in)
- FMX21: 3 x 0.227 mm² (3 x 26 AWG) + pressure compensation tube with Teflon filter
- FMX21 with Pt100 (optional): 7x 0.227 mm² (7x 26 AWG) + pressure compensation tube with Teflon filter
- Pressure compensation tube with Teflon filter: outer diameter 2.5 mm (0.1 in), internal diameter 1.5 mm (0.06 in)

Cable resistance of PE/PUR/FEP extension cable

- Cable resistance per wire: ≤ 0.09 Ω/m

Cable length of PE/PUR/FEP extension cable

- Please refer also to → 10, Chap. "Load".
- Cable length that can be ordered
 - Customer-specific length in meters or feet (→ 24, "Ordering information")
 - Limited cable length when performing installation with freely suspended device with extension cable mounting screw or mounting clamp, as well as for hazardous areas: max. 300 m (984 ft).
- When using the measuring device in hazardous areas, installation must comply with the applicable national standards and regulations and the Safety Instructions (XAs) or the Installation or Control Drawings (ZDs) "Additional documentation".

Further technical data for PE/PUR/FEP extension cable

- Minimum bending radius: 120 mm (4.72 in)
- Tensile strength: max. 950 N (213.56 lbf)
- Cable extraction force: typical ≥400 N (89.92 lbf) PE, FEP / typical ≥150 N (33.72 lbf) PUR
(The extension cable could be extracted from the level probe with a appropriate tensile force.)
- Resistance to UV light
- PE: Approved for use with drinking water

Terminals

- Three terminals as standard in the terminal box
- 4-terminal strip can be ordered as an accessory, Order No: 52008938
Conductor cross-section 0.08 to 2.5 mm² (28 to 14 AWG)

Note!

The 4-terminal strip is not intended for use in hazardous areas incl. CSA GP.

Human interface

Field Xpert SFX100

Field Xpert is an industrial PDA with integrated 3.5" touchscreen from Endress+Hauser based on Windows Mobile. It communicates via wireless with the optional VIATOR® Bluetooth® modem connected to a HART device point-to-point or wireless via WiFi and Endress+Hauser's Fieldgate FXA520. Field Xpert also works as a stand-alone device for asset management applications. For details refer to BA00060S/00/EN.

Field Communicator 375, 475

The Field Communicator 375, 475 handheld terminal can be used to set all the parameter via menu operation.

FieldCare

FieldCare is Endress+Hauser's plant asset management tool based on FDT technology. You can use FieldCare to configure all Endress+Hauser devices as well as third-party devices which support the FDT standard.

FieldCare supports the following functions:

- Configuration of transmitters in offline and online mode
- Loading and saving device data (upload/download)
- Documentation of the measuring point

Connection options:

- Via Commubox FXA195 and the USB port of a computer
- Via Fieldgate FXA520

For further information and free download of FieldCare see → www.endress.com → Download → Search: FieldCare

Certificates and approvals

CE mark	The device meets the legal requirements of the applicable EC Directives. Endress+Hauser confirms successful testing of the device by affixing to it the CE mark.
Approvals, types of protection	<ul style="list-style-type: none"> ■ ATEX II 2 G Ex ia IIC T4/T6 Gb ¹⁾²⁾ ■ ATEX II 3 G Ex nA IIC T5/T6 ¹⁾³⁾ ■ FM: IS Cl. I, Div. 1 Gp. A-D; AEx ia Cl. I Zone 1 IIC ¹⁾ ■ CSA C/US: IS Cl. I, Div. 1 Gp. A-D; Ex ia Cl. I Zone 1 IIC ¹⁾ ■ CSA: General Purpose ■ IEC Ex ia IIC T6 Gb ¹⁾ ■ NEPSI Ex ia IIC T6 <p>¹⁾ Only for Waterpilot FMX21 without Pt100 and TMT182</p> <p>²⁾ T4/T6: Temperature class T4 at $-10\text{ °C (+14 °F)} < T_a < +70\text{ °C (+158 °F)}$ Temperature class T6 at $-10\text{ °C (+14 °F)} < T_a < +40\text{ °C (+104 °F)}$</p> <p>³⁾ T5/T6: Temperature class T5 at $-10\text{ °C (+14 °F)} < T_a < +70\text{ °C (+158 °F)}$ Temperature class T6 at $-10\text{ °C (+14 °F)} < T_a < +60\text{ °C (+140 °F)}$</p> <p>Note!</p> <ul style="list-style-type: none"> ■ Waterpilot FMX21 is only available for use in hazardous areas with the FKM Viton seal. ■ All explosion-protection data are given in a separate documentation which is available upon request. The Ex documentation is provided with all Ex-systems as standards, see also →  28 "Additional documentation", "Safety instructions" and "Installation/Control Drawings".
Drinking water approval (for FMX21 with outer diameter 22 mm (0.87 in))	<ul style="list-style-type: none"> ■ KTW certificate ■ NSF 61 approval ■ ACS approval
Marine certificate	<ul style="list-style-type: none"> ■ GL (Germanischer Lloyd) ■ ABS (American Bureau of Shipping) ■ LR (Lloyds Register) ■ DNV (Det Norske Veritas)
Standards and guidelines applied	<p>The European standards and guidelines that have been applied are listed in the associated EC Declarations of Conformity. In addition, the following standards were also applied for the Waterpilot FMX21:</p> <ul style="list-style-type: none"> ■ DIN EN 60770 (IEC 60770): Transmitters for use in industrial process control systems Part 1: Methods for performance evaluation ■ DIN 16086: Electrical pressure measuring instruments, pressure sensors, pressure transmitters, pressure measuring instruments, concepts, specifications on data sheets ■ EN 61326: Electrical equipment for measurement, control and laboratory use – EMC requirements ■ EN 61010-1 (IEC 61010-1): Safety requirements for electrical equipment for measurement, control and laboratory use ■ EN 60529: Degrees of protection provided by enclosures

Ordering information

FMX21

You can enter the versions for the specific feature in the following table. The versions entered make up the complete order code. Options which are mutually exclusive are not marked.

10	Approval:		
	AA	Non-hazardous area	
	BE	ATEX II 2 G Ex ia IIC T6	
	BD	ATEX II 3 G Ex nA IIC T6	
	FE	FM IS, Cl. I Division 1, Groups A – D, AEx ia, zone 1	
	CE	CSA C/US IS Cl. I Division 1, Groups A – D, Ex ia, zone 1	
	CD	CSA General Purpose	
	IC	IEC Ex ia IIC T6 Gb	
	NA	NEPSI Ex ia IIC T6	
20	Output:		
	2	4-20 mA HART	
45	Probe tube:		
	1	Outer diameter d = 22 mm, AISI 316L	
	2	Outer diameter d = 42 mm, flush-mounted, AISI 316L	
	5	Outer diameter d = 29 mm, AISI 316L, PPS/polyolefin for saltwater applications	
70	Sensor range:		
	Measuring range		
	1C	100 mbar/10 kPa/1.5 psi gauge, 1mH ₂ O/3ftH ₂ O/40inH ₂ O	
	1D	200 mbar/20 kPa/3 psi gauge, 2mH ₂ O/6ftH ₂ O/80inH ₂ O	
	1F	400 mbar/40 kPa/6 psi gauge, 4mH ₂ O/13ftH ₂ O/160inH ₂ O	
	1G	600 mbar/60 kPa/9 psi gauge, 6mH ₂ O/20ftH ₂ O/240inH ₂ O	
	1H	1 bar/100 kPa/15 psi gauge, 10mH ₂ O/33ftH ₂ O/400inH ₂ O	
	1K	2 bar/200 kPa/30 psi gauge, 20mH ₂ O/67ftH ₂ O/800inH ₂ O	
	1M	4 bar/400 kPa/60 psi gauge, 40mH ₂ O/133ftH ₂ O/1600inH ₂ O	
	1P	10 bar/1 MPa/150 psi gauge, 100mH ₂ O/333ftH ₂ O/4000inH ₂ O	
	1Q	20 bar/2 MPa/300 psi gauge, 200mH ₂ O/667ftH ₂ O/8000inH ₂ O	
	2K	2 bar/200 kPa/30 psi absolute, 20mH ₂ O/67ftH ₂ O/800inH ₂ O	
	2M	4 bar/400 kPa/60 psi absolute, 40mH ₂ O/133ftH ₂ O/1600inH ₂ O	
	2P	10 bar/1 MPa/150 psi absolute, 100mH ₂ O/333ftH ₂ O/4000inH ₂ O	
	2Q	20 bar/2 MPa/300 psi absolute, 200mH ₂ O/667ftH ₂ O/8000inH ₂ O	
80	Reference accuracy:		
	D	Platinum	
	G	Standard	
90	Calibration, unit:		
	A	Sensor range; %	
	B	Sensor range; mbar/bar	
	C	Sensor range; kPa/MPa	
	D	Sensor range; mm/mH ₂ O	
	E	Sensor range; inH ₂ O/ftH ₂ O	
	F	Sensor range; psi	
	J	Customized pressure; see additional specification	
	K	Customized level; see additional specification	
FMX21-			Order code

→ Ordering information for FMX21 continued on next page.

FMX21 (continued)

100						Probe connection:
	10	10 m cable, shortable, PE				
	11	20 m cable, shortable, PE				
	15 m cable, shortable, PE				
	20	30 ft cable, shortable, PE				
	21	60 ft cable, shortable, PE				
	25 ft cable, shortable, PE				
	30	10 m cable, shortable, FEP				
	31	20 m cable, shortable, FEP				
	35 m cable, shortable, FEP				
	40	30 ft cable, shortable, FEP				
	41	60 ft cable, shortable, FEP				
	45 ft cable, shortable, FEP				
	50	10 m cable, shortable, PUR				
	51	20 m cable, shortable, PUR				
55 m cable, shortable, PUR					
60	30 ft cable, shortable, PUR					
61	60 ft cable, shortable, PUR					
65 ft cable, shortable, PUR					
190						Seal:
	A	FKM Viton				
	H	EPDM				
FMX21-						Order code

Additional ordering information (optional)

550						Calibration
	F1	Works calib. certificate 5-point				
570						Service
	IA	Adjusted min alarm current				
	IB	Adjusted HART Burst Mode PV				
	IR	... m cable marking>installation				
	IS	... ft cable marking>installation				
	I9	Special version				
590						Additional approval
	LE	GL Marine certificate				
	LF	ABS Marine certificate				
	LG	LR Marine certificate				
	LI	DNV Marine certificate				
	LQ	KTW potable water approval				
	LR	NSF potable water approval				
LS	ACS potable water approval					
610						Accessories mounted
	NB	Temperature sensor Pt100, 4-wire				
620						Accessories enclosed
	PO	Suspension clamp, 316L				
	PQ	Cable mounting screw G1-1/2, 304				
	PR	Cable mounting screw NPT1-1/2, 304				
	PS	Terminal box IP66/67				
	PT	Temperature head transmitter TMT182, 2-wire, 4-20 mA, -20 to 80 °C				
	PU	Additional weight, 316L				
	PV	Adapter, function test				
	PW	Shortening kit, extension cable				
895						Marking
	Z1	Tagging (TAG)				
FMX21-						Order code

Accessories

Mounting clamp

- Endress+Hauser offers a mounting clamp for easy FMX21 mounting → [18](#).
- Material: 1.4404 (AISI 316L) and fiberglass reinforced PA (polyamide)
- Order number 52006151, see also "Ordering information" → [24](#),

Terminal box

- IP66/IP67 terminal boxes with GORE-TEX® filter incl. 3 integrated terminals.
The terminal box is also suitable for installing a TMT182 temperature head transmitter or for four additional terminals (Order No. 52008938) → [19](#).
- "Ordering information" → [24](#)

Note!

The terminal box is not intended for the FMX21 with Ex nA explosion protection in the hazardous area.

Additional weight (for FMX21 with outer diameter of 22 mm (0.87 in) or 29 mm (1.14 in))

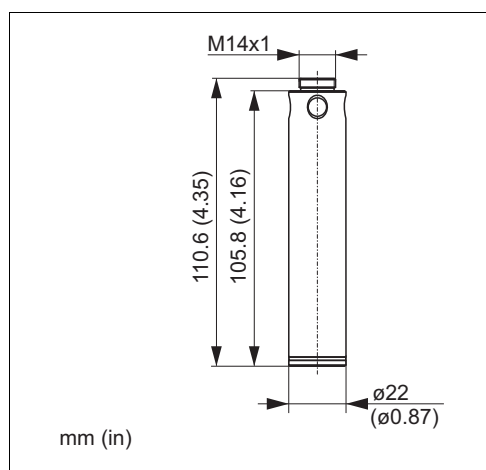

- Endress+Hauser offers additional weights to prevent sideways movement that results in measuring errors, or to make it easier to lower the device in a guide tube.
You can screw several weights together. The weights are then attached directly to the FMX21. For FMX21 with an outer diameter of 29 mm (1.14 in) a maximum of 5 weights may be attached. In combination with the Ex nA approval, for FMX21 with an outer diameter of 29 mm (1.14 in) a maximum of 1 additional weight may be attached.
- Material: 1.4435 (AISI 316L)
- Weight: 300 g (10.581 oz)
- Order number 52006153, see also "Ordering information" → [24](#)

TMT182 temperature head transmitter (4 to 20 mA/ HART)

- 2-wire temperature head transmitter, configured for a measuring range from -20 to $+80$ °C (-4 to $+158$ °F). This setting offers a temperature range of 100 K which can be easily mapped. Please note that the Pt100 resistance thermometer is designed for a temperature range from -10 to $+70$ °C (-14 to $+176$ °F) → [20](#).
- "Ordering information" → [24](#),

Note!

The TM182 temperature head transmitter is not intended for use in hazardous areas incl. CSA GP.

Extension cable mounting screw

- Endress+Hauser offers extension cable mounting screws to ease FMX21 mounting and to seal the measuring aperture → [19](#).
- Material: 1.4301 (AISI 304)
- order number 52008264 (G1 ½ A thread), order number 52009311 (NPT1 ½ thread), see also "Ordering information" → [24](#)

Terminals

- Four terminals in strip for terminal box, suitable for wire cross-section: 0.08 to 2.5 mm² (28 to 14 AWG)
- Order number: 52008938

Note!

The 4-terminal strip is not intended for use in hazardous areas incl. CSA GP.

Cable shortening kit

- The cable shortening kit is used to easily and professionally shorten a cable.
- → [24](#), "Ordering information" and the documentation SD00552P/00/A6.

Note!

The cable shortening kit is not intended for the FMX21 with FM/CSA approval.

**Installation tool –
indicating the customer-
specific length on the cable**

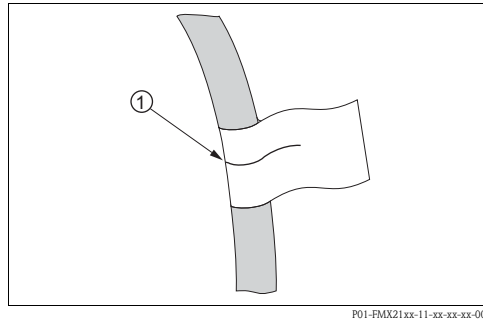

1 cable marking, distance to the lower end of the cable probe

- To make installation easier, Endress+Hauser offers a mark on the extension cable for a customer-specific length, see also → 24 "Ordering information".
- Mark tolerance: up to ±50 mm (1.97 in)
(The mark tolerance corresponds to a measured error from up to ±50 mm (1.97 in).
- Material: PET
- Adhesive: acrylic
- Immunity to temperature change:
-30 to +100 °C (-22 to +212 °F)

Note!

The mark is for installation purposes only.

The mark must be thoroughly removed without trace in the case of devices with drinking water approval. The extension cable must not be damaged in the process.

**Testing adapter
(for FMX21 with outer
diameter of 22 mm (0.87 in)
and 29 mm (1.14 in))**

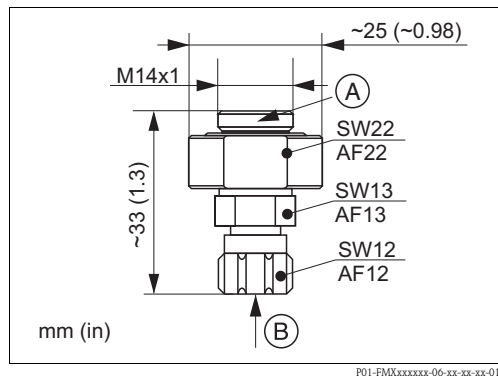

Testing adapter

- A FMX21 level probe connection
- B Compressed air hose connection, internal diameter of quick coupling piece 4 mm (0.16 in)

- Endress+Hauser offers a testing adapter to ease function-testing of the level probes.
- Observe the maximum pressure for the compressed air hose and the maximum overload for the level probe → 24.
- Maximum pressure of the quick coupling piece supplied: 10 bar (145 psi)
- Adapter material: 1.4301 (AISI 304)
- Quick coupling piece material: anodized aluminum
- Adapter weight: 39 g (1.376 oz)
- Order number 52011868, see also → 24 "Ordering information".

Additional documentation

Field of activities	<ul style="list-style-type: none">■ Pressure measurement: FA00004P/00/EN■ Recording technology: FA00014R/09/EN■ System components: FA00016K/09/EN
Technical Information	<ul style="list-style-type: none">■ Technical Information Waterpilot FMX167 with 4 to 20 mA analog output: TI00351P/00/EN■ Technical Information Deltapilot M: TI00437P/00/EN■ Temperature head transmitter iTEMP HART TMT182: TI00078R/09/EN
Operating Instructions	<ul style="list-style-type: none">■ Waterpilot FMX21: BA00380P/00/EN■ Cable shortening kit: SD00552P/00/A6■ Field Xpert: BA00060S/04/EN
Safety instructions	<ul style="list-style-type: none">■ ATEX II 2 G: XA00454P/00/A3■ ATEX II 3 G: XA00485P/00/A3■ IECEX Ex ia IIC: XA00455P/00/EN■ NEPSI Ex ia IIC: XA00456P/00/B2
Installation/ Control Drawings	<ul style="list-style-type: none">■ FM IS Cl. I, Div. 1, Gp. A – D / Cl. I Zone 1 IIC: ZD00231P/00/EN■ CSA C/US IS Cl. I, Div. 1, Gp. A – D / Cl. I Zone 1, IIC: ZD00232P/00/EN
Drinking water approval	<ul style="list-style-type: none">■ SD00289P/00/A3 (NSF)■ SD00319P/00/A3 (KTW)■ SD00320P/00/A3 (ACS)

Pressure

The following configuration data sheet has to be filled in and included with the order if the option "J: customized pressure" has been selected in feature "090: Calibration; unit" in the product structure.

Pressure Engineering Unit (a)

- | | | | |
|-------------------------------|--------------------------------|----------------------------------|------------------------------|
| <input type="checkbox"/> mbar | <input type="checkbox"/> mmH2O | <input type="checkbox"/> mmHg | <input type="checkbox"/> Pa |
| <input type="checkbox"/> bar | <input type="checkbox"/> mH2O | | <input type="checkbox"/> kPa |
| | <input type="checkbox"/> ftH2O | | <input type="checkbox"/> MPa |
| <input type="checkbox"/> psi | <input type="checkbox"/> inH2O | <input type="checkbox"/> kgf/cm2 | |

Calibration Range / Output

LRV: _____ [pressure engineering unit]
URV: _____ [pressure engineering unit]

Damping

Damping ____ sec

Instruments International

Endress+Hauser
Instruments International AG
Kaegenstrasse 2
4153 Reinach
Switzerland

Tel. +41 61 715 81 00
Fax +41 61 715 25 00
www.endress.com
info@ii.endress.com

Endress+Hauser 
People for Process Automation

