

Lightning/surge arrester type 1/2 - VAL-MS-EE-T1/T2-3+1-335 - 2910551

Please be informed that the data shown in this PDF Document is generated from our Online Catalog. Please find the complete data in the user's documentation. Our General Terms of Use for Downloads are valid (<http://phoenixcontact.com/download>)



Universal varistor-based plug-in lightning/surge arrester for 3-phase power supply networks with separate N and PE (5-conductor system: L1, L2, L3, N, PE), for Lightning Protection Levels III and IV.



Key Commercial Data

Packing unit	1 pc
GTIN	
GTIN	4055626462370
Weight per Piece (excluding packing)	638.000 g
Weight per piece (including packing)	672.400 g
Custom tariff number	85363030
Country of origin	Germany
Note	Made to Order (non-returnable)

Technical data

Dimensions

Height	89.8 mm
Width	71.2 mm
Depth	77.5 mm (incl. DIN rail 7.5 mm)
Horizontal pitch	4 Div.

Ambient conditions

Degree of protection	IP20 (only when all terminal points are used)
Ambient temperature (operation)	-40 °C ... 80 °C
Ambient temperature (storage/transport)	-40 °C ... 80 °C
Altitude	≤ 2000 m (amsl (above mean sea level))
Permissible humidity (operation)	5 % ... 95 %
Shock (operation)	30g (Half-sine / 11 ms / 3x ±X, ±Y, ±Z)
Vibration (operation)	7.5g (10 ... 500 Hz / 2.5 h / X, Y, Z)

Lightning/surge arrester type 1/2 - VAL-MS-EE-T1/T2-3+1-335 - 2910551

Technical data

General

IEC test classification	I / II
	T1 / T2
EN type	T1 / T2
IEC power supply system	TT
	TN-S
Mode of protection	L-N
	L-PE
	N-PE
Mounting type	DIN rail: 35 mm
Color	traffic grey B RAL 7043
Housing material	PA 6.6
	PBT
Degree of pollution	2
Flammability rating according to UL 94	V-0
Type	DIN rail module, two-section, divisible
Surge protection fault message	optical

Protective circuit

Nominal voltage U_N	240/415 V AC (TN-S)
	240/415 V AC (TT)
Nominal frequency f_N	50 Hz (60 Hz)
Maximum continuous operating voltage U_C (L-N)	335 V AC
Maximum continuous operating voltage U_C (L-PE)	335 V AC
Maximum continuous voltage U_C (N-PE)	264 V AC
Rated load current I_L	80 A
Residual current I_{PE}	$\leq 5 \mu A$
Standby power consumption P_C	$\leq 810 \text{ mVA}$
Nominal discharge current I_n (8/20) μs (L-N)	12.5 kA
Nominal discharge current I_n (8/20) μs (L-PE)	12.5 kA
Nominal discharge current I_n (8/20) μs (N-PE)	50 kA
Maximum discharge current I_{max} (8/20) μs	50 kA
Impulse discharge current (10/350) μs (L-N), charge	6.25 As
Impulse discharge current (10/350) μs (L-N), specific energy	39 kJ/ Ω
Impulse discharge current (10/350) μs (L-N), peak current value I_{imp}	12.5 kA
Impulse discharge current (10/350) μs (L-PE), charge	6.25 As
Impulse discharge current (10/350) μs (L-PE), specific energy	39 kJ/ Ω
Impulse discharge current (10/350) μs (L-PE), peak current value I_{imp}	12.5 kA
Impulse discharge current (10/350) μs (N-PE), charge	25 As
Impulse discharge current (10/350) μs (N-PE), specific energy	625 kJ/ Ω
Impulse discharge current (10/350) μs (N-PE), peak current value I_{imp}	50 kA

Lightning/surge arrester type 1/2 - VAL-MS-EE-T1/T2-3+1-335 - 2910551

Technical data

Protective circuit

Total discharge current I_{total} (8/20) μ s	50 kA
Total discharge current I_{total} (10/350) μ s	50 kA
Follow current interrupt rating I_{fi} (N-PE)	100 A
Short-circuit current rating I_{SCCR}	25 kA
Voltage protection level U_p (L-N)	≤ 1.2 kV
	≤ 1.6 kV (30 kA - 8/20 μ s)
Voltage protection level U_p (L-PE)	≤ 2 kV
Voltage protection level U_p (N-PE)	≤ 1.7 kV
Residual voltage U_{res} (L-N)	≤ 1.2 kV (at I_n)
	≤ 1.1 kV (at 10 kA)
	≤ 1 kV (at 5 kA)
	≤ 0.9 kV (at 3 kA)
Residual voltage U_{res} (L-PE)	≤ 2 kV (at I_n)
	≤ 1.5 kV (at 10 kA)
	≤ 1.2 kV (at 5 kA)
	≤ 1.1 kV (at 3 kA)
Residual voltage U_{res} (N-PE)	≤ 0.6 kV (at I_n)
	≤ 0.5 kV (at 10 kA)
	≤ 0.5 kV (at 5 kA)
	≤ 0.4 kV (at 3 kA)
TOV behavior at U_T (L-N)	415 V AC (5 s / withstand mode)
	457 V AC (120 min / safe failure mode)
TOV behavior at U_T (N-PE)	1200 V AC (200 ms / withstand mode)
Response time t_A (L-N)	≤ 25 ns
Response time t_A (L-PE)	≤ 100 ns
Response time t_A (N-PE)	≤ 100 ns
Max. backup fuse with V-type through wiring	80 A (gG - 16 mm ²)
Max. backup fuse with branch wiring	160 A (gG)

Connection data

Connection method	Screw connection
Screw thread	M5
Tightening torque	3 Nm (1.5 mm ² ... 16 mm ²)
	4.5 Nm (25 mm ² ... 35 mm ²)
Stripping length	16 mm
Conductor cross section flexible	1.5 mm ² ... 25 mm ²
Conductor cross section solid	1.5 mm ² ... 35 mm ²
Conductor cross section AWG	15 ... 2
Connection method	Biconnect terminal blocks
Conductor cross section flexible	1.5 mm ² ... 16 mm ²

Lightning/surge arrester type 1/2 - VAL-MS-EE-T1/T2-3+1-335 - 2910551

Technical data

Standards and Regulations

Standards/regulations	IEC 61643-11 2011
	EN 61643-11 2012

Environmental Product Compliance

China RoHS	Environmentally Friendly Use Period = 50 years
	For details about hazardous substances go to tab "Downloads", Category "Manufacturer's declaration"

Drawings

Dimensional drawing

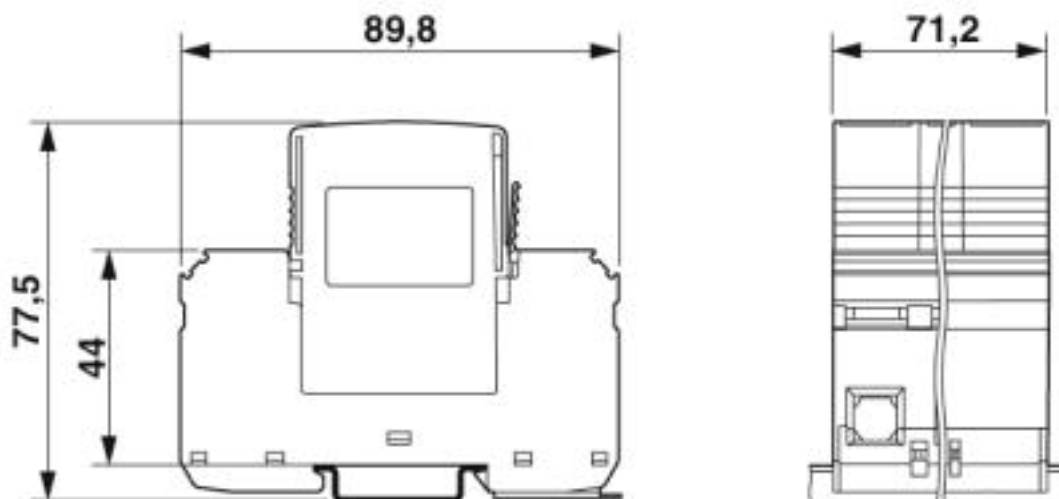

Lightning/surge arrester type 1/2 - VAL-MS-EE-T1/T2-3+1-335 - 2910551

Circuit diagram

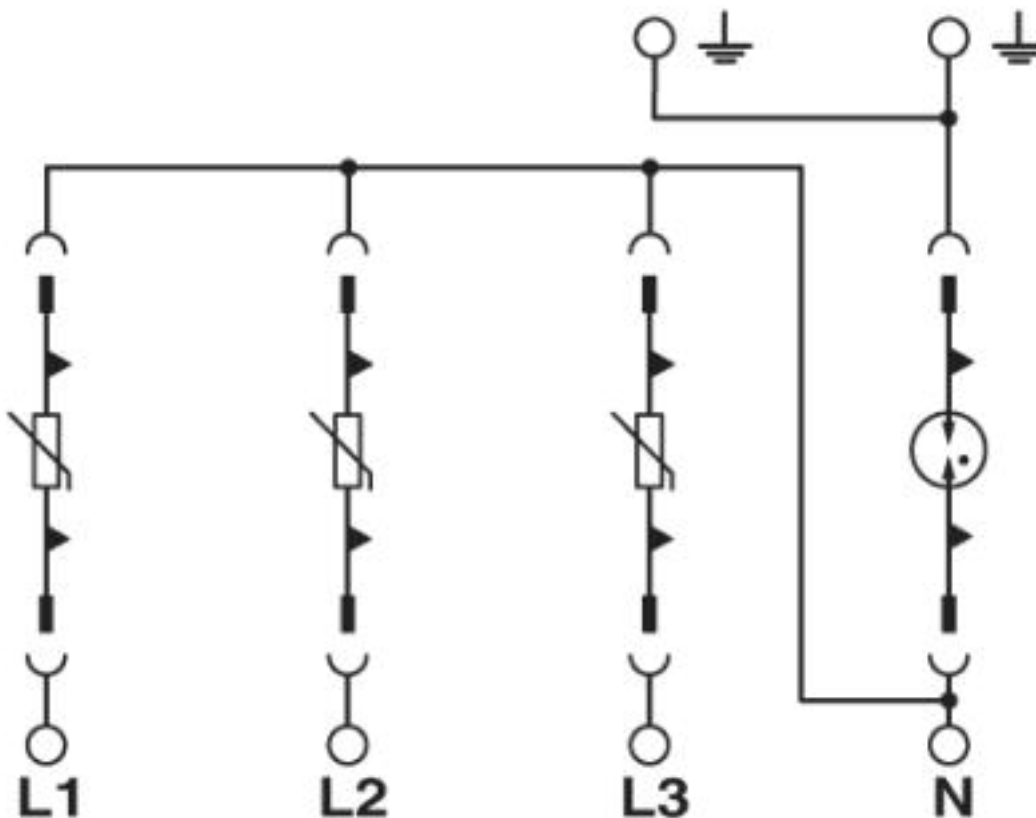

Classifications

eCl@ss

eCl@ss 4.0	27140201
eCl@ss 4.1	27130801
eCl@ss 5.0	27130801
eCl@ss 5.1	27130801
eCl@ss 6.0	27130800
eCl@ss 7.0	27130805
eCl@ss 8.0	27130805
eCl@ss 9.0	27130805

ETIM

ETIM 2.0	EC000941
ETIM 3.0	EC000941
ETIM 4.0	EC000381
ETIM 5.0	EC000941
ETIM 6.0	EC000941
ETIM 7.0	EC000941

Lightning/surge arrester type 1/2 - VAL-MS-EE-T1/T2-3+1-335 - 2910551

Classifications

UNSPSC

UNSPSC 6.01	30212010
UNSPSC 7.0901	39121610
UNSPSC 11	39121610
UNSPSC 12.01	39121610
UNSPSC 13.2	39121620
UNSPSC 18.0	39121620
UNSPSC 19.0	39121620
UNSPSC 20.0	39121620
UNSPSC 21.0	39121620

Accessories

Accessories

Device marking

Zack marker strip - ZBN 18:UNBEDRUCKT - 2809128



Zack marker strip, Strip, white, unlabeled, can be labeled with: CMS-P1-PLOTTER, PLOTMARK, mounting type: snap into tall marker groove, for terminal block width: 18 mm, lettering field size: 18 x 5 mm, Number of individual labels: 5

Feed-through terminal block

Feed-through terminal block - DK-BIC-35 - 2749880



Feed-through terminal block for VAL and FLT applications

Labeled device marker

Marker for terminal blocks - ZBN 18,LGS:ERDE - 2749589



Marker for terminal blocks, Strip, white, labeled, Horizontal: Grounding symbol, mounting type: snap into tall marker groove, for terminal block width: 18 mm, lettering field size: 18 x 5 mm, Number of individual labels: 5

Lightning/surge arrester type 1/2 - VAL-MS-EE-T1/T2-3+1-335 - 2910551

Accessories

Marker for terminal blocks - ZBN 18,LGS:L1-N,ERDE - 2749576



Marker for terminal blocks, Strip, white, labeled, Horizontal: L1, L2, L3, N, GND, mounting type: snap into tall marker groove, for terminal block width: 18 mm, lettering field size: 18 x 5 mm, Number of individual labels: 5

Marker pen

Marker pen - B-STIFT - 1051993



Marker pen, for manual labeling of unprinted Zack strips, smear-proof and waterproof, line thickness 0.5 mm

Spare parts

Type 1/2 surge protection plug - VAL-MS-EE-T1/T2-335-P - 2910556



L-N replacement plug for VAL-MS-T1/T2 335/12.5 plug-in lightning/surge arrester.

Type 1/2 surge protection plug - F-MS-EE-T1/T2-50-P - 2910557



N-PE replacement plug for VAL-MS-T1/T2 335/12.5 plug-in lightning/surge arrester.