

# Uninterruptible power supply - QUINT4-UPS/24DC/24DC/40 - 2907077

Please be informed that the data shown in this PDF Document is generated from our Online Catalog. Please find the complete data in the user's documentation. Our General Terms of Use for Downloads are valid (<http://phoenixcontact.com/download>)



QUINT UPS with IQ Technology, for DIN rail mounting, input: 24 V DC, output: 24 V DC / 40 A, charging current: 5 A

## Product Description

The intelligent QUINT UPS for integration into established industrial networks: your systems continue to be supplied with uninterrupted power, even in the event of a mains failure. The battery management system with IQ Technology and a powerful battery charger ensures superior system availability.

## Your advantages

- ✓ Easy integration into networks using PROFINET, EtherNet/IP, EtherCAT® and USB interfaces
- ✓ Evaluation of state of health (SOH) and state of charge (SOC), thanks to the intelligent battery management system (BMS)
- ✓ Automatic recognition of the battery capacities and technologies (VRLA-WTR, LI-ION)
- ✓ Monitoring of output current and voltage, as well as manual connection and disconnection of the system
- ✓ SFB Technology selectively trips standard miniature circuit breakers. Loads connected in parallel continue working.



## Key Commercial Data

Packing unit	1 pc
GTIN	 4 055626 170053
GTIN	4055626170053
Weight per Piece (excluding packing)	739.300 g
Weight per piece (including packing)	739.300 g
Custom tariff number	85371091
Country of origin	China

## Technical data

### Dimensions

Width	47 mm
Height	130 mm
Depth	125 mm
Width with alternative assembly	123 mm

# Uninterruptible power supply - QUINT4-UPS/24DC/24DC/40 - 2907077

## Technical data

### Dimensions

Height with alternative assembly	130 mm
Depth with alternative assembly	49 mm

### Ambient conditions

Degree of protection	IP20
Inflammability class in acc. with UL 94 (housing / terminal blocks)	V0
Ambient temperature (operation)	-25 °C ... 70 °C (> 60 °C Derating: 2.5 %/K)
Ambient temperature (start-up type tested)	-40 °C
Ambient temperature (storage/transport)	-40 °C ... 85 °C
Max. permissible relative humidity (operation)	≤ 95 % (at 25 °C, non-condensing)
Climatic class	3K3 (EN 60721)
Degree of pollution	2
Installation height	≤ 4000 m

### Input data

Input voltage	24 V DC
Input voltage range	18 V DC ... 30 V DC
Electric strength, max.	35 V DC (Protected against polarity reversal)
Internal input fuse	no
Inrush current	≤ 9 A (≤ 4 ms)
Reverse polarity protection	yes
Fixed backup threshold	22 V DC
Switch-on time	max. 3 s
Voltage drop, input/output	0.5 V DC

### Output data (general)

Short-circuit-proof	yes
No-load proof	yes
Switch-over time	0 ms
UPS connection in parallel	no
UPS connection in series	no
Energy storage device connection in parallel	Yes, 5 (observe line protection)
Energy storage device connection in series	no
Efficiency	typ. 98 %

### Output data (mains operation)

Output voltage range	18 V DC ... 30 V DC
	18 V DC ... 32 V DC
Static Boost ( $I_{Stat.Boost}$ )	45 A
Dynamic Boost ( $I_{Dyn.Boost}$ )	60 A (5 s)
Selective Fuse Breaking ( $I_{SFB}$ )	215 A (15 ms)

### Output data (battery operation)

# Uninterruptible power supply - QUINT4-UPS/24DC/24DC/40 - 2907077

## Technical data

### Output data (battery operation)

Output voltage range	19 V DC ... 32 V DC
Static Boost ( $I_{Stat.Boost}$ )	45 A
Dynamic Boost ( $I_{Dyn.Boost}$ )	60 A (5 s)
Selective Fuse Breaking ( $I_{SFB}$ )	215 A (15 ms)

### Energy storage (battery)

Battery technology	VRLA, VRLA-WTR, LI-ION
End-of-charge voltage (temperature-compensated)	25 V DC ... 32 V DC
Max. capacity	135 Ah
Nominal capacity (without additional charger)	7 Ah ... 135 Ah
Charging current (configurable)	max. 5 A
Charging time	500 min. (38 Ah)
Buffer time	33 min. (38 Ah)
Temperature compensation (configurable)	42 mV/K
Charge characteristic curve	IU <sub>0</sub> U
Temperature sensor	yes
IQ-Technology	yes

### General data

Inflammability class in acc. with UL 94 (housing / terminal blocks)	V0
MTBF (IEC 61709, SN 29500)	> 1980000 h (25 °C)
	> 1205000 h (40 °C)
	> 604200 h (60 °C)
Life expectancy (electrolytic capacitors)	126720 h
Weight	0.7 kg
Environmental protection directive	RoHS
	WEEE
	Reach

### Connection data, input

Connection method	Screw connection
Conductor cross section solid min.	0.5 mm <sup>2</sup>
Conductor cross section solid max.	16 mm <sup>2</sup>
Conductor cross section flexible min.	0.5 mm <sup>2</sup>
Conductor cross section flexible max.	16 mm <sup>2</sup>
Single conductor/terminal point, stranded, with ferrule, min.	0.5 mm <sup>2</sup>
Single conductor/terminal point, stranded, with ferrule, max.	16 mm <sup>2</sup>
Conductor cross section AWG min.	8
Conductor cross section AWG max.	6
Stripping length	10 mm
Tightening torque, min	1.2 Nm
Tightening torque max	1.5 Nm

# Uninterruptible power supply - QUINT4-UPS/24DC/24DC/40 - 2907077

## Technical data

### Connection data output

Connection method	Screw connection
Conductor cross section solid min.	0.5 mm <sup>2</sup>
Conductor cross section solid max.	16 mm <sup>2</sup>
Conductor cross section flexible min.	0.5 mm <sup>2</sup>
Conductor cross section flexible max.	16 mm <sup>2</sup>
Single conductor/terminal point, stranded, with ferrule, min.	0.5 mm <sup>2</sup>
Single conductor/terminal point, stranded, with ferrule, max.	16 mm <sup>2</sup>
Conductor cross section AWG min.	8
Conductor cross section AWG max.	6
Stripping length	10 mm
Tightening torque, min	1.2 Nm
Tightening torque max	1.5 Nm

### Connection data for battery

Connection method	Screw connection
Conductor cross section solid min.	0.5 mm <sup>2</sup>
Conductor cross section solid max.	16 mm <sup>2</sup>
Conductor cross section flexible min.	0.5 mm <sup>2</sup>
Conductor cross section flexible max.	16 mm <sup>2</sup>
Conductor cross section AWG min.	8
Conductor cross section AWG max.	6
Stripping length	10 mm
Tightening torque, min	1.2 Nm
Tightening torque max	1.5 Nm

### Standards

EMC requirements for noise immunity	EN 61000-6-1
	EN 61000-6-2
EMC requirements for noise emission	EN 61000-6-3
	EN 61000-6-4
Standard designation	Safety extra-low voltage
Standards/regulations	IEC 61010-1 (SELV)
	IEC 61010-2-201 (PELV)

### Conformance/approvals

Designation	UL approval
Identification	UL/C-UL Listed UL 61010-1
Designation	UL approval
Identification	UL/C-UL Listed UL 61010-2-201
Designation	UL approval
Identification	UL/C-UL Listed ANSI/ISA-12.12.01 Class I, Division 2, Groups A, B, C, D T4 (Hazardous Location)
Designation	CSA

# Uninterruptible power supply - QUINT4-UPS/24DC/24DC/40 - 2907077

## Technical data

### Conformance/approvals

Identification	CAN/CSA-C22.2 No. 61010-1-12
Designation	CSA
Identification	CAN/CSA-IEC 61010-2-201
Designation	CSA
Identification	CAN/CSA-C22.2 No. 213 Class I, Division 2, Groups A, B, C, D T4 (Hazardous Location)
Designation	CB scheme
Identification	IEC 61010-1
	IEC 61010-2-201

### EMC data

Electromagnetic compatibility	Conformance with EMC Directive 2014/30/EU
Low Voltage Directive	Conformance with Low Voltage Directive 2014/35/EC
Electrostatic discharge	EN 61000-4-2
Contact discharge	8 kV (Test Level 4)
Discharge in air	15 kV (Test Level 4)
Electromagnetic HF field	EN 61000-4-3
Frequency range	80 MHz ... 1 GHz
Test field strength	20 V/m (Test Level 3)
Frequency range	1 GHz ... 6 GHz
Test field strength	10 V/m (Test Level 3)
Frequency range	1 GHz ... 6 GHz
Test field strength	10 V/m (Test Level 3)
Comments	Criterion A
Fast transients (burst)	EN 61000-4-4
Input	4 kV (Test Level 4 - asymmetrical)
Output	4 kV (Test Level 4 - asymmetrical)
Signal	4 kV (Test Level 4 - asymmetrical)
Comments	Criterion B
Surge voltage load (surge)	EN 61000-4-5
Input	1 kV (Test Level 3 - symmetrical)
	2 kV (Test Level 3 - asymmetrical)
Output	1 kV (Test Level 3 - symmetrical)
	2 kV (Test Level 3 - asymmetrical)
Signal	1 kV (Test Level 2 - asymmetrical)
Comments	Criterion B
I/O/S	asymmetrical
Frequency range	0.15 MHz ... 80 MHz
Voltage	10 V (Test Level 3)
Comments	Criterion A
Frequency	16.67 Hz

# Uninterruptible power supply - QUINT4-UPS/24DC/24DC/40 - 2907077

## Technical data

### EMC data

	50 Hz
	60 Hz
Test field strength	100 A/m
Additional text	60 s
Comments	Criterion A
Frequency	50 Hz
	60 Hz
Test field strength	1 kA/m
Additional text	3 s
Frequency	0 Hz
Test field strength	300 A/m
Additional text	DC, 60 s
Criterion A	Normal operating behavior within the specified limits.
Criterion B	Temporary impairment to operational behavior that is corrected by the device itself.

### Environmental Product Compliance

REACH SVHC	Lead 7439-92-1
------------	----------------

## Drawings

# Uninterruptible power supply - QUINT4-UPS/24DC/24DC/40 - 2907077

Block diagram

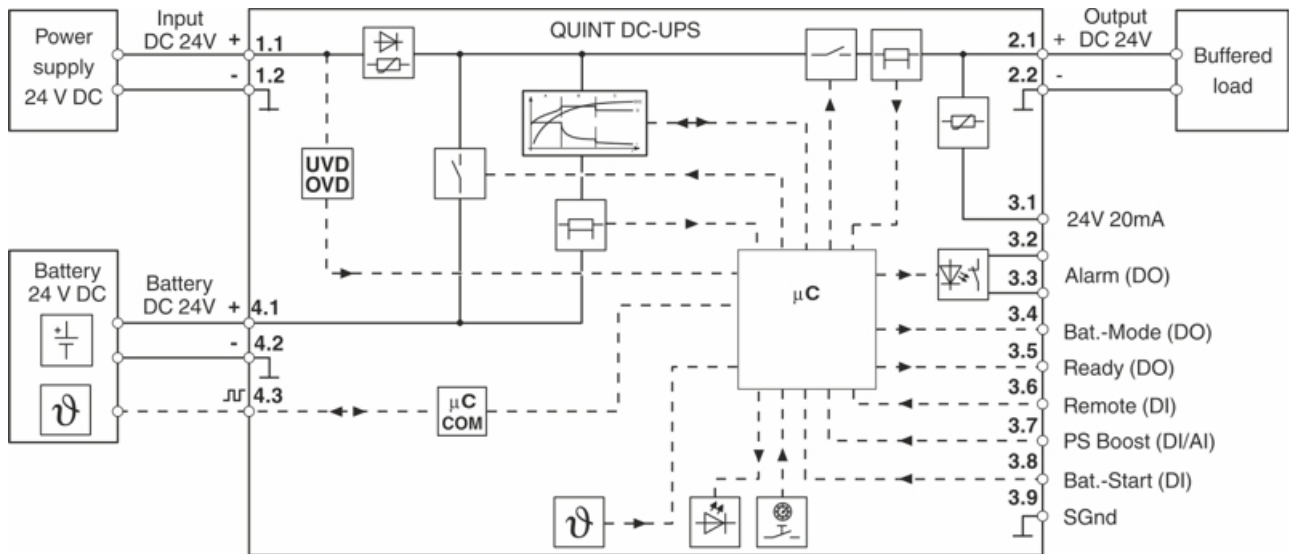

## Classifications

eCl@ss

eCl@ss 5.1	27242213
eCl@ss 8.0	27242209
eCl@ss 9.0	27040705

ETIM

ETIM 5.0	EC000599
ETIM 6.0	EC000382
ETIM 7.0	EC000382

UNSPSC

UNSPSC 13.2	39121004
UNSPSC 18.0	39121011
UNSPSC 19.0	39121011
UNSPSC 20.0	39121011
UNSPSC 21.0	39121011

# Uninterruptible power supply - QUINT4-UPS/24DC/24DC/40 - 2907077

## Approvals

### Approvals

---

#### Approvals

UL Listed / cUL Listed / EAC / cULus Listed

---

#### Ex Approvals

UL Listed / cUL Listed / cULus Listed

---

### Approval details

UL Listed		<a href="http://database.ul.com/cgi-bin/XYV/template/LISEXT/1FRAME/index.htm">http://database.ul.com/cgi-bin/XYV/template/LISEXT/1FRAME/index.htm</a>	FILE E 123528
-----------	--	---	---------------

cUL Listed		<a href="http://database.ul.com/cgi-bin/XYV/template/LISEXT/1FRAME/index.htm">http://database.ul.com/cgi-bin/XYV/template/LISEXT/1FRAME/index.htm</a>	FILE E 123528
------------	--	---	---------------

EAC			RU*DE*08.B.01873/19
-----	--	--	---------------------

cULus Listed			
--------------	--	--	--

## Accessories

### Accessories

#### Battery unit

Energy storage - UPS-BAT/VRLA/24DC/7.2AH - 2320319



Energy storage device, lead AGM, VRLA technology, 24 V DC, 7.2 Ah, tool-free battery replacement, automatic detection, and communication with QUINT UPS-IQ

---



## Uninterruptible power supply - QUINT4-UPS/24DC/24DC/40 - 2907077

### Accessories

#### Energy storage - UPS-BAT/VRLA/24DC/12AH - 2320322



Energy storage device, lead AGM, VRLA technology, 24 V DC, 12 Ah, tool-free battery replacement, automatic detection, and communication with QUINT UPS-IQ

---

#### Energy storage - UPS-BAT/VRLA/24DC/38AH - 2320335



Energy storage device, lead AGM, VRLA technology, 24 V DC, 38 Ah, automatic detection, and communication with QUINT UPS-IQ

---

#### Energy storage - UPS-BAT/VRLA-WTR/24DC/13AH - 2320416



Energy storage device, lead AGM, VRLA technology, 24 V DC, 13 Ah, tool-free battery replacement, automatic detection, and communication with QUINT UPS-IQ

---

#### Energy storage - UPS-BAT/VRLA-WTR/24DC/26AH - 2320429



Energy storage device, lead AGM, VRLA technology, 24 V DC, 26 Ah, tool-free battery replacement, automatic detection, and communication with QUINT UPS-IQ

---

#### Energy storage - UPS-BAT/LI-ION/24DC/120WH - 2320351



Energy storage device, LI-ION technology, 24 V DC, 120 Wh, for ambient temperatures of -20°C ... 60°C, automatic detection and communication with QUINT UPS-IQ

---

# Uninterruptible power supply - QUINT4-UPS/24DC/24DC/40 - 2907077

## Accessories

Energy storage - UPS-BAT/LI-ION/24DC/924WH - 2908232



Energy storage device, LI-ION technology, 24 V DC, 924 Wh, for ambient temperatures of -25 °C ... 60 °C, automatic detection and communication with QUINT UPS-IQ