

## Safety relays - PSR-MS25-1NO-1DO-24DC-SC - 2904951

Please be informed that the data shown in this PDF Document is generated from our Online Catalog. Please find the complete data in the user's documentation. Our General Terms of Use for Downloads are valid (<http://phoenixcontact.com/download>)



Safety relay for emergency stop and safety doors up to SILCL 1, Cat. 1, PL c, depending on the application up to SILCL 3, Cat. 4, PL e, 1-channel operation, manual, monitored start, 1 enabling current path,  $U_s = 24 \text{ V DC}$ , fixed screw terminal block

### Why buy this product

- Up to Cat. 1/PL c according to ISO 13849-1, SILCL 1 according to IEC 62061
- Depending on the application, up to Cat. 4/PL e according to ISO 13849-1, SILCL 3 according to IEC 62061
- Low housing width of just 6.8 mm
- Single-channel control
- 1 enabling current path, 1 digital signal output
- Manual and monitored activation



### Key Commercial Data

Packing unit	1 STK
GTIN	 4 046356 904995
GTIN	4046356904995
Weight per Piece (excluding packing)	69.000 g
Weight per piece (including packing)	84.000 g
Custom tariff number	85371098
Country of origin	Germany

### Technical data

#### Note

Utilization restriction	EMC: class A product, see manufacturer's declaration in the download area
-------------------------	---

#### Dimensions

Width	6.8 mm
Height	93.1 mm

# Safety relays - PSR-MS25-1NO-1DO-24DC-SC - 2904951

## Technical data

### Dimensions

Depth	102.5 mm
-------	----------

### Ambient conditions

Ambient temperature (operation)	-40 °C ... 60 °C (observe derating)
Ambient temperature (storage/transport)	-40 °C ... 85 °C
Max. permissible relative humidity (operation)	75 % (on average, 85% infrequently, non-condensing)
Max. permissible humidity (storage/transport)	75 % (on average, 85% infrequently, non-condensing)
Maximum altitude	≤ 2000 m (Above sea level)

### Input data

Rated control circuit supply voltage $U_s$	24 V DC -15 % / +10 %
Rated control supply current $I_s$	typ. 42 mA
Power consumption at $U_s$	typ. 1 W
Inrush current	4.5 A ( $\Delta t = 120 \mu s$ at $U_s$ )
	< 20 mA (with $U_s/I_x$ to S12)
	< 10 mA (with $U_s/I_x$ at the start circuit)
Current consumption	< 5 mA (with $U_s/I_x$ to S12)
	< 10 mA (with $U_s/I_x$ at the start circuit)
Voltage at input/start and feedback circuit	24 V DC -15 % / +10 %
Typical response time	< 175 ms
Typical release time	< 20 ms (when controlled via A1 or S12)
Recovery time	< 500 ms
Operating voltage display	1 x green LED
Status display	2 x green LEDs
Protective circuit	Surge protection Suppressor diode
	Protection against polarity reversal for rated control circuit supply voltage
Maximum switching frequency	0.5 Hz
Max. permissible overall conductor resistance	150 $\Omega$
Filter time	1 ms (at A1 in the event of voltage dips at $U_s$ )
	max. 1.5 ms (at S12; test pulse width)
	min. 7.5 ms (at S12; test pulse rate)
	Test pulse rate = 5 x Test pulse width

### Output data

Contact type	1 enabling current path
Contact material	AgSnO <sub>2</sub>
Maximum switching voltage	250 V AC/DC (Observe the load curve)
Minimum switching voltage	12 V AC/DC
Limiting continuous current	6 A (observe derating)
Maximum inrush current	6 A
Inrush current, minimum	3 mA
Sq. Total current	36 A <sup>2</sup> (observe derating)

# Safety relays - PSR-MS25-1NO-1DO-24DC-SC - 2904951

## Technical data

### Output data

Switching capacity	min. 60 mW
Mechanical service life	10 x 10 <sup>6</sup> cycles
Output fuse	6 A gL/gG (N/O contact)
	4 A gL/gG (for low-demand applications)

### Alarm outputs

Number of outputs	1 (digital, PNP)
Voltage	22 V DC (U <sub>s</sub> - 2 V)
Current	max. 100 mA
Maximum inrush current	500 mA (Δt = 1 ms at U <sub>s</sub> )
Short-circuit protection	no

### General

Relay type	Electromechanical relay with forcibly guided contacts in accordance with IEC/EN 61810-3 (EN 50205)
Nominal operating mode	100% operating factor
Net weight	69 g
Mounting type	DIN rail mounting
Assembly instructions	See derating curve
Mounting position	vertical or horizontal
Degree of protection	IP20
Min. degree of protection of inst. location	IP54
Housing material	PBT
Housing color	yellow

### Connection data

Connection method	Screw connection
pluggable	no
Conductor cross section solid min.	0.2 mm <sup>2</sup>
Conductor cross section solid max.	2.5 mm <sup>2</sup>
Conductor cross section flexible min.	0.2 mm <sup>2</sup>
Conductor cross section flexible max.	2.5 mm <sup>2</sup>
Conductor cross section AWG min.	26
Conductor cross section AWG max.	12
Stripping length	12 mm
Screw thread	M3

### Safety-related characteristic data

Stop category	0
Designation	IEC 61508 - High demand
Safety Integrity Level (SIL)	1 (up to SIL 3 depending on the application)
Designation	IEC 61508 - Low demand
Safety Integrity Level (SIL)	1 (up to SIL 3 depending on the application)

# Safety relays - PSR-MS25-1NO-1DO-24DC-SC - 2904951

## Technical data

### Safety-related characteristic data

Designation	EN ISO 13849
Performance level (PL)	c (up to PL e depending on the application)
Category	1 (up to Cat. 4 depending on the application)
Designation	EN 62061
Safety Integrity Level Claim Limit (SIL CL)	1 (up to SILCL 3 depending on the application)

### Standards and Regulations

Designation	Air clearances and creepage distances between the power circuits
Standards/regulations	DIN EN 50178
Rated insulation voltage	250 V AC
	250 V AC
Rated surge voltage/insulation	Safe isolation, reinforced insulation 6 kV between input circuit and enabling current path Basic insulation 4 kV between all current paths and housing
Degree of pollution	2
Overvoltage category	III
Shock	15g
Vibration (operation)	10 Hz ...150 Hz, 2g
Conformance	CE-compliant

### Environmental Product Compliance

China RoHS	Environmentally Friendly Use Period = 50
	For details about hazardous substances go to tab "Downloads", Category "Manufacturer's declaration"

## Drawings

Block diagram

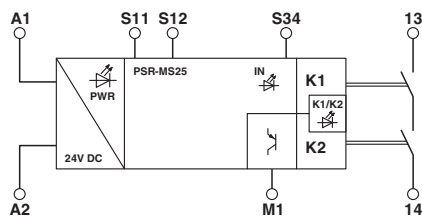

Block diagram

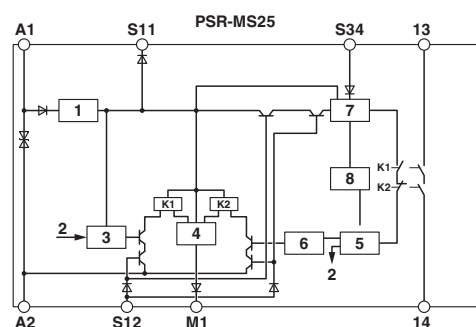

Key:

- 1 = Voltage limitation
- 2 = Channel 1
- 3 = Control circuit channel 1
- 4 = Control circuit signal output
- 5 = Start channel 1 and 2
- 6 = Control circuit channel 2
- 7 = Start circuit

# Safety relays - PSR-MS25-1NO-1DO-24DC-SC - 2904951

8 = Diagnostics  
 K1, K2 = Force-guided elementary relays

Application drawing

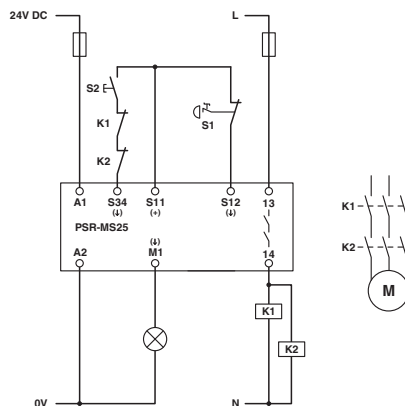

## Classifications

eCl@ss

eCl@ss 5.1	27371901
eCl@ss 6.0	27371819
eCl@ss 8.0	27371819
eCl@ss 9.0	27371819

ETIM

ETIM 5.0	EC001449
ETIM 6.0	EC001449

UNSPSC

UNSPSC 13.2	39121501
-------------	----------

## Approvals

Approvals

Approvals

UL Listed / cUL Listed / Functional Safety / EAC / cULus Listed

Ex Approvals

Approval details

UL Listed		<a href="http://database.ul.com/cgi-bin/XYV/template/LISEXT/1FRAME/index.htm">http://database.ul.com/cgi-bin/XYV/template/LISEXT/1FRAME/index.htm</a>	FILE E 140324
-----------	--	---	---------------

## Safety relays - PSR-MS25-1NO-1DO-24DC-SC - 2904951

### Approvals

cUL Listed		<a href="http://database.ul.com/cgi-bin/XYV/template/LISEXT/1FRAME/index.htm">http://database.ul.com/cgi-bin/XYV/template/LISEXT/1FRAME/index.htm</a>	FILE E 140324
------------	---	---	---------------

Functional Safety	44-205-13755202
-------------------	-----------------

EAC		RU C- DE.A*30.B.01082
-----	---	--------------------------

cULus Listed	
--------------	---