

Power supply, with protective coating - QUINT-PS/1AC/24DC/10/CO - 2320911

Please be informed that the data shown in this PDF Document is generated from our Online Catalog. Please find the complete data in the user's documentation. Our General Terms of Use for Downloads are valid (<http://phoenixcontact.com/download>)



Primary-switched QUINT POWER power supply for DIN rail mounting with SFB (Selective Fuse Breaking) Technology, with protective coating, input: 1-phase, output: 24 V DC/10 A

Product Description

QUINT POWER power supplies with maximum functionality

QUINT POWER circuit breakers magnetically and therefore quickly trip at six times the nominal current, for selective and therefore cost-effective system protection. In addition, the high system availability is ensured by preventive function monitoring which reports critical operating states before errors can occur.

Reliable starting of heavy loads takes place via the static power reserve POWER BOOST. Thanks to the adjustable voltage, all ranges between 18 V DC ... 29.5 V DC are covered.

Your advantages

- ✓ For superior system availability
- ✓ Reliable starting of difficult loads with the static POWER BOOST power reserve with up to 1.5 times the nominal current permanently
- ✓ Fast tripping of standard circuit breakers with dynamic power reserve SFB (selective fuse breaking) technology with up to 6 times the nominal current for 12 ms
- ✓ Preventive function monitoring
- ✓ Optimum protection with dip coating for 100 % humidity



Key Commercial Data

| | |
|--------------------------------------|---------------------|
| Packing unit | 1 pc |
| GTIN | 4 046356 520027 |
| GTIN | 4046356520027 |
| Weight per Piece (excluding packing) | 1,100.000 g |
| Weight per piece (including packing) | 1,544.500 g |
| Custom tariff number | 85044030 |
| Country of origin | Thailand |

Power supply, with protective coating - QUINT-PS/1AC/24DC/10/ CO - 2320911

Technical data

Dimensions

| | |
|----------------------------------|--------|
| Width | 60 mm |
| Height | 130 mm |
| Depth | 125 mm |
| Width with alternative assembly | 122 mm |
| Height with alternative assembly | 130 mm |
| Depth with alternative assembly | 63 mm |

Ambient conditions

| | |
|--|--|
| Degree of protection | IP20 |
| Ambient temperature (operation) | -40 °C ... 70 °C (> 60 °C Derating: 2.5 %/K) |
| Ambient temperature (storage/transport) | -40 °C ... 85 °C |
| Max. permissible relative humidity (operation) | 100 % (at 25 °C, non-condensing) |
| Climatic class | 3K3 (in acc. with EN 60721) |
| Degree of pollution | 2 |
| Installation height | 5000 m |

Input data

| | |
|--|--|
| Nominal input voltage range | 100 V AC ... 240 V AC |
| | 110 V DC ... 250 V DC |
| Input voltage range | 85 V AC ... 264 V AC |
| | 90 V DC ... 410 V DC +5 % (UL 508: ≤ 250 V DC) |
| Dielectric strength maximum | 300 V AC |
| AC frequency range | 45 Hz ... 65 Hz |
| Frequency range DC | 0 Hz |
| Discharge current to PE | < 3.5 mA |
| Current consumption | 2.2 A (120 V AC) |
| | 1.3 A (230 V AC) |
| | 2.5 A (110 V DC) |
| | 1.2 A (220 V DC) |
| Nominal power consumption | 303 VA |
| Inrush current | < 15 A |
| Mains buffering time | typ. 36 ms (120 V AC) |
| | typ. 36 ms (230 V AC) |
| Input fuse | 10 A (slow-blow, internal) |
| Recommended breaker for input protection | 10 A ... 20 A (AC: Characteristics B, C, D, K) |
| Type of protection | Transient surge protection |
| Protective circuit/component | Varistor, gas-filled surge arrester |

Output data

| | |
|------------------------|--------------|
| Nominal output voltage | 24 V DC ±1 % |
|------------------------|--------------|

Power supply, with protective coating - QUINT-PS/1AC/24DC/10/CO - 2320911

Technical data

Output data

| | |
|--|---|
| Setting range of the output voltage (U_{Set}) | 18 V DC ... 29.5 V DC (> 24 V DC, constant capacity restricted) |
| Nominal output current (I_N) | 10 A (-25 °C ... 60 °C, $U_{OUT} = 24$ V DC) |
| POWER BOOST (I_{Boost}) | 15 A (-25°C ... 40°C permanent, $U_{OUT} = 24$ V DC) |
| Selective Fuse Breaking (I_{SFB}) | 60 A (12 ms) |
| Derating | 60 °C ... 70 °C (2.5%/K) |
| Connection in parallel | Yes, for redundancy and increased capacity |
| Connection in series | yes |
| Feedback voltage resistance | max. 35 V DC |
| Protection against overvoltage at the output (OVP) | < 32 V DC |
| Control deviation | < 1 % (change in load, static 10 % ... 90 %) |
| | < 2 % (change in load, dynamic 10 % ... 90 %) |
| | < 0.1 % (change in input voltage ± 10 %) |
| Residual ripple | < 50 mV _{PP} (with nominal values) |
| Output power | 240 W |
| Typical response time | < 0.15 s |
| Maximum power dissipation in no-load condition | 9.1 W |
| Power loss nominal load max. | 22 W |

General

| | |
|---------------------------------|---|
| Net weight | 1.1 kg |
| Efficiency | > 92.5 % (for 230 V AC and nominal values) |
| MTBF (IEC 61709, SN 29500) | > 940000 h (25 °C) |
| | > 530000 h (40 °C) |
| | > 230000 h (60 °C) |
| Insulation voltage input/output | 4 kV AC (type test) |
| | 2 kV AC (routine test) |
| Insulation voltage input / PE | 3.5 kV AC (type test) |
| | 2 kV AC (routine test) |
| Insulation voltage output / PE | 500 V DC (routine test) |
| Degree of protection | IP20 |
| Protection class | I |
| Mounting position | horizontal DIN rail NS 35, EN 60715 |
| Assembly instructions | alignable: $P_N \geq 50\%$, 5 mm horizontally, 15 mm next to active components, 50 mm vertically alignable: $P_N < 50\%$, 0 mm horizontally, 40 mm vertically top, 20 mm vertically bottom |

Connection data, input

| | |
|------------------------------------|----------------------------|
| Connection method | Pluggable screw connection |
| Conductor cross section solid min. | 0.2 mm ² |
| Conductor cross section solid max. | 2.5 mm ² |

Power supply, with protective coating - QUINT-PS/1AC/24DC/10/CO - 2320911

Technical data

Connection data, input

| | |
|---------------------------------------|---------------------|
| Conductor cross section flexible min. | 0.2 mm ² |
| Conductor cross section flexible max. | 2.5 mm ² |
| Conductor cross section AWG min. | 16 |
| Conductor cross section AWG max. | 12 |
| Stripping length | 7 mm |
| Screw thread | M3 |

Connection data, output

| | |
|---------------------------------------|----------------------------|
| Connection method | Pluggable screw connection |
| Conductor cross section solid min. | 0.2 mm ² |
| Conductor cross section solid max. | 2.5 mm ² |
| Conductor cross section flexible min. | 0.2 mm ² |
| Conductor cross section flexible max. | 2.5 mm ² |
| Conductor cross section AWG min. | 16 |
| Conductor cross section AWG max. | 12 |
| Stripping length | 7 mm |
| Screw thread | M3 |

Connection data for signaling

| | |
|---------------------------------------|---------------------|
| Conductor cross section solid min. | 0.2 mm ² |
| Conductor cross section solid max. | 2.5 mm ² |
| Conductor cross section flexible min. | 0.2 mm ² |
| Conductor cross section flexible max. | 2.5 mm ² |
| Conductor cross section AWG min. | 16 |
| Conductor cross section AWG max. | 12 |
| Screw thread | M3 |

Standards

| | |
|--|---|
| EMC requirements for noise immunity | EN 61000-6-1 |
| | EN 61000-6-2 |
| EMC requirements for noise emission | EN 61000-6-3 |
| | EN 61000-6-4 |
| HART FSK Physical Layer Test Specification Compliance | Output voltage U _{Out} compliant |
| Standard - Electrical safety | IEC 60950-1/VDE 0805 (SELV) |
| Standard – Electronic equipment for use in electrical power installations and their assembly into electrical power installations | EN 50178/VDE 0160 (PELV) |
| Standard – Safety extra-low voltage | IEC 60950-1 (SELV) and EN 60204-1 (PELV) |
| Standard - Safe isolation | DIN VDE 0100-410 |
| Standard – Limitation of mains harmonic currents | EN 61000-3-2 |
| Standard - Equipment safety | BG (design tested) |
| Explosive atmosphere | EN 60079-15 (Zone 2) |

Power supply, with protective coating - QUINT-PS/1AC/24DC/10/CO - 2320911

Technical data

Standards

| | |
|------------------------------|--------------------------------------|
| Mains variation/undervoltage | SEMI F47-0706 Compliance Certificate |
| Rail applications | EN 50121-4 |
| | EN 50155 |
| | EN 50121-3-2 |
| | EN 61373 |

Conformance/approvals

| | |
|-----------------------|--|
| UL approvals | UL/C-UL listed UL 508 |
| | UL/C-UL Recognized UL 60950-1 |
| | UL ANSI/ISA-12.12.01 Class I, Division 2, Groups A, B, C, D (Hazardous Location) |
| CSA | CAN/CSA-C22.2 No. 60950-1-07 |
| | CSA-C22.2 No. 107.1-01 |
| SIQ | BG (type approved) |
| Shipbuilding approval | DNV GL (EMC B), ABS, LR, RINA, NK, BV |
| DeviceNet approval | DeviceNet™ Power Supply Conformance Tested |

EMC data

| | |
|-------------------------------|---|
| Electromagnetic compatibility | Conformance with EMC Directive 2014/30/EU |
| Low Voltage Directive | Conformance with Low Voltage Directive 2014/35/EC |
| Electrostatic discharge | EN 61000-4-2 |
| Contact discharge | 8 kV (Test Level 4) |
| Discharge in air | 15 kV (Test Level 4) |
| Electromagnetic HF field | EN 61000-4-3 |
| Frequency range | 80 MHz ... 1 GHz |
| Test field strength | 20 V/m (Test Level 3) |
| Frequency range | 1 GHz ... 2 GHz |
| Test field strength | 10 V/m (Test Level 3) |
| Frequency range | 2 GHz ... 3 GHz |
| Test field strength | 10 V/m (Test Level 3) |
| Comments | Criterion A |
| Fast transients (burst) | EN 61000-4-4 |
| Input | 4 kV (Test Level 4 - asymmetrical) |
| Output | 2 kV (Test Level 3 - asymmetrical) |
| Signal | 2 kV (Test Level 4 - asymmetrical) |
| Comments | Criterion A |
| Surge voltage load (surge) | EN 61000-4-5 |
| Input | 2 kV (Test Level 3 - symmetrical) |
| | 4 kV (Test Level 4 - asymmetrical) |
| Output | 1 kV (Test Level 2 - symmetrical) |
| | 2 kV (Test Level 3 - asymmetrical) |

Power supply, with protective coating - QUINT-PS/1AC/24DC/10/CO - 2320911

Technical data

EMC data

| | |
|-----------------|--|
| Signal | 1 kV (Test Level 2 - asymmetrical) |
| Comments | Criterion A |
| I/O/S | asymmetrical |
| Frequency range | 0.15 MHz ... 80 MHz |
| Voltage | 10 V (Test Level 3) |
| Comments | Criterion A |
| Criterion A | Normal operating behavior within the specified limits. |
| Criterion B | Temporary impairment to operational behavior that is corrected by the device itself. |

Environmental Product Compliance

| | |
|------------|---|
| REACH SVHC | Lead 7439-92-1 |
| China RoHS | Environmentally Friendly Use Period = 25; |
| | For details about hazardous substances go to tab "Downloads", Category "Manufacturer's declaration" |

Drawings

Block diagram

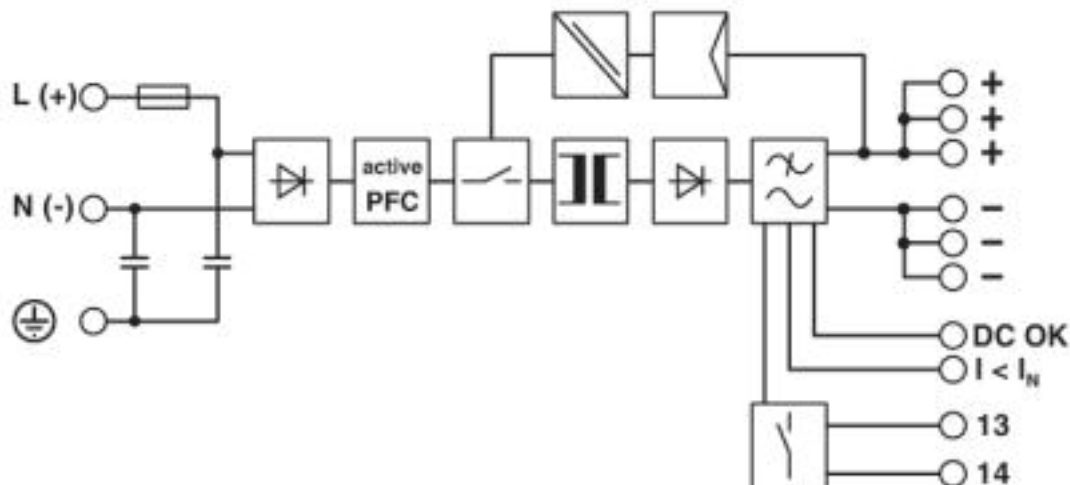

Classifications

eCl@ss

| | |
|------------|----------|
| eCl@ss 4.0 | 27040700 |
| eCl@ss 4.1 | 27040700 |
| eCl@ss 5.0 | 27049000 |
| eCl@ss 5.1 | 27049000 |
| eCl@ss 6.0 | 27049000 |

Power supply, with protective coating - QUINT-PS/1AC/24DC/10/CO - 2320911

Classifications

eCl@ss

| | |
|------------|----------|
| eCl@ss 7.0 | 27049002 |
| eCl@ss 8.0 | 27049002 |
| eCl@ss 9.0 | 27040701 |

ETIM

| | |
|----------|----------|
| ETIM 4.0 | EC000599 |
| ETIM 5.0 | EC002540 |
| ETIM 6.0 | EC002540 |
| ETIM 7.0 | EC002540 |

UNSPSC

| | |
|---------------|----------|
| UNSPSC 6.01 | 30211502 |
| UNSPSC 7.0901 | 39121004 |
| UNSPSC 11 | 39121004 |
| UNSPSC 12.01 | 39121004 |
| UNSPSC 13.2 | 39121004 |
| UNSPSC 18.0 | 39121004 |
| UNSPSC 19.0 | 39121004 |
| UNSPSC 20.0 | 39121004 |
| UNSPSC 21.0 | 39121004 |

Approvals

Approvals

Approvals

DNV GL / CSA / BV / LR / NK / ABS / RINA / UL Listed / UL Recognized / cUL Recognized / IECEx CB Scheme / cUL Listed / EAC / Type approved / EAC / cULus Recognized / cULus Listed

Ex Approvals

IECEx / ATEX / UL Listed / cUL Listed / cULus Listed

Approval details

| | | | |
|--------|--|---|------------|
| DNV GL | | https://approvalfinder.dnvgl.com/ | TAE000014W |
|--------|--|---|------------|

Power supply, with protective coating - QUINT-PS/1AC/24DC/10/ CO - 2320911

Approvals

| | | | |
|-----------------|--|---|------------------------|
| CSA | | http://www.csagroup.org/services-industries/product-listing/ | 1897786 |
| BV | | http://www.veristar.com/portal/veristarinfo/generalinfo/approved/approvedProducts/equipmentAndMaterials | 21004-C0 BV |
| LR | | http://www.lr.org/en | 08/20069 E4 |
| NK | | http://www.classnk.or.jp/hp/en/ | 08A039 |
| ABS | | http://www.eagle.org/eagleExternalPortalWEB/ | 15- HG1375463-1-PDA |
| RINA | | http://www.rina.org/en | ELE316517XG |
| UL Listed | | http://database.ul.com/cgi-bin/XYV/template/LISEXT/1FRAME/index.htm | FILE E 123528 |
| UL Recognized | | http://database.ul.com/cgi-bin/XYV/template/LISEXT/1FRAME/index.htm | FILE E 211944 |
| cUL Recognized | | http://database.ul.com/cgi-bin/XYV/template/LISEXT/1FRAME/index.htm | FILE E 211944 |
| IECEE CB Scheme | | http://www.iecee.org/ | SI-6154 |

Power supply, with protective coating - QUINT-PS/1AC/24DC/10/CO - 2320911

Approvals

| | | | |
|------------|--|---|---------------|
| cUL Listed | | http://database.ul.com/cgi-bin/XYV/template/LISEXT/1FRAME/index.htm | FILE E 123528 |
|------------|--|---|---------------|

| | | | |
|-----|--|--|---------------|
| EAC | | | EAC-Zulassung |
|-----|--|--|---------------|

| | | | |
|---------------|--|--|-------------------|
| Type approved | | | SI-SIQ BG 005/008 |
|---------------|--|--|-------------------|

| | | | |
|-----|--|--|---------------------|
| EAC | | | RU*DE*08.B.01873/19 |
|-----|--|--|---------------------|

| | | | |
|------------------|--|--|--|
| cULus Recognized | | | |
|------------------|--|--|--|

| | | | |
|--------------|--|--|--|
| cULus Listed | | | |
|--------------|--|--|--|

Accessories

Accessories

Assembly adapter

Assembly adapters - UWA 182/52 - 2938235



Universal wall adapter for securely mounting the device in the event of strong vibrations. The device is screwed directly onto the mounting surface. The universal wall adapter is attached on the top/bottom.

Power supply, with protective coating - QUINT-PS/1AC/24DC/10/CO - 2320911

Accessories

Assembly adapters - QUINT-PS-ADAPTERS7/2 - 2938206



Assembly adapter for QUINT POWER 10A on S7-300 rail

Device protection

Type 3 surge protection device - PLT-SEC-T3-230-FM-UT - 2907919



Type 2/3 surge protection, consisting of protective plug and base element with screw connection. For single-phase power supply network with integrated status indicator and remote signaling. Nominal voltage 230 V AC/DC.

Type 3 surge protection device - PLT-SEC-T3-24-FM-UT - 2907916



Type 3 surge protection, consisting of protective plug and base element, with integrated status indicator and remote signaling for single-phase power supply networks. Nominal voltage 24 V AC/DC.

Fan

Fan - QUINT-PS/FAN/4 - 2320076



The fan for QUINT-PS/1AC and .../3AC can be mounted without the need for tools or other accessories. By using the fan, optimum cooling is ensured at high ambient temperatures or if the mounting position is rotated.

Mounting rail adapter

DIN rail adapter - UTA 107 - 2853983

Universal DIN rail adapter, for screwing on switchgear



Power supply, with protective coating - QUINT-PS/1AC/24DC/10/CO - 2320911

Accessories

Redundancy module

Diode - QUINT-DIODE/12-24DC/2X20/1X40 - 2320157



DIN rail diode module 12-24 V DC/2x20 A or 1x40 A. Uniform redundancy up to the consumer.

Redundancy module, with protective coating - QUINT-ORING/24DC/2X10/1X20 - 2320173



Active QUINT redundancy module for DIN rail mounting with Auto Current Balancing ACB technology and monitoring functions, input: 24 V DC, output: 24 V DC/2 x 10 A or 1 x 20 A, including mounted UTA 107/30 universal DIN rail adapter

Redundancy module - TRIO-DIODE/12-24DC/2X10/1X20 - 2866514



Redundancy module with function monitoring, 12 ... 24 V DC, 2x 10 A, 1x 20 A

Thermomagnetic device circuit breakers

Thermomagnetic device circuit breaker - CB TM1 1A SFB P - 2800836



Thermomagnetic device circuit breaker, 1-pos., tripping characteristic SFB, 1 PDT contact, plug for base element.

Thermomagnetic device circuit breaker - CB TM1 2A SFB P - 2800837



Thermomagnetic device circuit breaker, 1-pos., tripping characteristic SFB, 1 PDT contact, plug for base element.

Power supply, with protective coating - QUINT-PS/1AC/24DC/10/ CO - 2320911

Accessories

Thermomagnetic device circuit breaker - CB TM1 3A SFB P - 2800838



Thermomagnetic device circuit breaker, 1-pos., tripping characteristic SFB, 1 PDT contact, plug for base element.

Thermomagnetic device circuit breaker - CB TM1 4A SFB P - 2800839



Thermomagnetic device circuit breaker, 1-pos., tripping characteristic SFB, 1 PDT contact, plug for base element.

Thermomagnetic device circuit breaker - CB TM1 5A SFB P - 2800840



Thermomagnetic device circuit breaker, 1-pos., tripping characteristic SFB, 1 PDT contact, plug for base element.
