

Mounting frame - VS-SI-EB-EMV-2 - 1656495

Please be informed that the data shown in this PDF Document is generated from our Online Catalog. Please find the complete data in the user's documentation. Our General Terms of Use for Downloads are valid (<http://phoenixcontact.com/download>)

Mounting frame, for two front plates or sockets, metal frame, matt nickel-plated, electrically conductive, transparent cover



RoHS

Key Commercial Data

Packing unit	1 STK
GTIN	
GTIN	4046356029865
Weight per Piece (excluding packing)	402.400 g
Weight per piece (including packing)	402.400 g
Custom tariff number	85389099
Country of origin	Czech Republic

Technical data

Dimensions

Height	35 mm
Width	130 mm
Length	120 mm
Length of the assembly cutout	91 mm
Width of the assembly cutout	117 mm

Ambient conditions

Degree of protection of housing (IP)	IP65
Ambient temperature (operation)	-10 °C ... 60 °C

General

Type	For 2 front plates
Housing material	Zinc alloy
Housing surface material	Nickel-plated
Flammability rating according to UL 94	V0

Mounting frame - VS-SI-EB-EMV-2 - 1656495

Technical data

General

Assembly instructions	Suitable for panel thicknesses 1 mm ... 5 mm
-----------------------	--

Standards and Regulations

Flammability rating according to UL 94	V0
--	----

Drawings

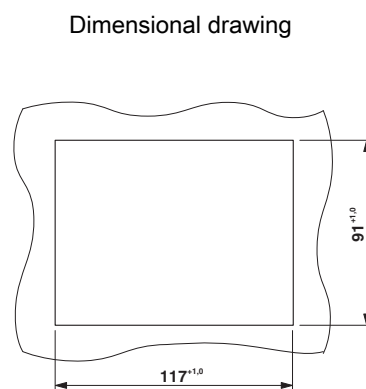
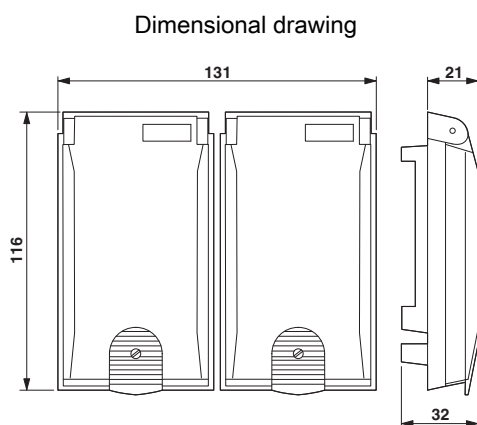

Dimensional drawing

Mounting cutout

Classifications

eCl@ss

eCl@ss 4.0	27140816
eCl@ss 4.1	27140816
eCl@ss 5.0	27189239
eCl@ss 5.1	27189239
eCl@ss 6.0	27144001
eCl@ss 7.0	27144001
eCl@ss 8.0	27144001
eCl@ss 9.0	27144001

ETIM

ETIM 2.0	EC000007
ETIM 3.0	EC000007
ETIM 4.0	EC000007
ETIM 5.0	EC000007
ETIM 6.0	EC000007

UNSPSC

UNSPSC 6.01	31261501
UNSPSC 7.0901	31261501

Mounting frame - VS-SI-EB-EMV-2 - 1656495

Classifications

UNSPSC

UNSPSC 11	31261501
UNSPSC 12.01	31261501
UNSPSC 13.2	31261501

Approvals

Approvals

Approvals

EAC / EAC

Ex Approvals

Approval details

EAC		EAC-Zulassung
-----	--	---------------

EAC		RU C- DE.A*30.B.01102
-----	--	--------------------------

Accessories

Accessories

Marking material

Marker labels - VS-SI-BZ - 1656660



Marker label, plastic, plate with 20 labels

Socket

Mounting frame - VS-SI-EB-EMV-2 - 1656495

Accessories

Socket insert - VS-SI-SD-DE - 1656505



Ground contact socket, plastic, for Germany

Socket insert - VS-SI-SD-DE-G - 1656518



Socket insert, degree of protection: IP20, material: PA, connection method: Screw connection, color: yellow, Germany

Socket insert - VS-SI-SD-USA - 1656521



Ground contact socket, plastic, for USA

Socket insert - VS-SI-SD-FR - 1656534



Ground contact socket, plastic, for France

Socket insert - VS-SI-SD-GB - 1656547



Ground contact socket, plastic, for Great Britain

Mounting frame - VS-SI-EB-EMV-2 - 1656495

Accessories

Socket insert - VS-SI-SD-IT - 1656550



Ground contact socket, plastic, for Italy