

Philips screwdriver - SZK PZ1 VDE - 1206450

Please be informed that the data shown in this PDF Document is generated from our Online Catalog. Please find the complete data in the user's documentation. Our General Terms of Use for Downloads are valid (<http://phoenixcontact.com/download>)



Screwdriver, PZ crosshead, VDE insulated, size: PZ 1 x 80 mm, 2-component grip, with non-slip grip

Your advantages

- VDE approval
- Screwdrivers for Phillips screws with Pozidriv and Phillips Recess screw head

Key Commercial Data

| | |
|--------------------------------------|---|
| Packing unit | 10 pc |
| GTIN |  4 017918 170912 |
| GTIN | 4017918170912 |
| Weight per Piece (excluding packing) | 60.700 g |
| Weight per piece (including packing) | 60.700 g |
| Custom tariff number | 82054000 |
| Country of origin | Czech Republic |

Technical data

Dimensions

| | |
|--------------|--------|
| Length (b) | 178 mm |
| Width (a) | 33 mm |
| Blade width | 3 mm |
| Blade height | 80 mm |
| Wrench size | 0 mm |

General

| | |
|---------------|--------------------|
| Type | Phillips |
| | 1 |
| Material | alloyed tool steel |
| Test standard | DIN/ISO 8764-1 PZ |
| Weight | 60 g |

Standards and Regulations

| | |
|---------------|-------------------|
| Test standard | DIN/ISO 8764-1 PZ |
|---------------|-------------------|

Philips screwdriver - SZK PZ1 VDE - 1206450

Technical data

Environmental Product Compliance

| | |
|---------------------------|---|
| California Proposition 65 | Further information on California's prop. 65 is available under "Downloads" in the manufacturer's declaration |
|---------------------------|---|

Drawings

Dimensional drawing

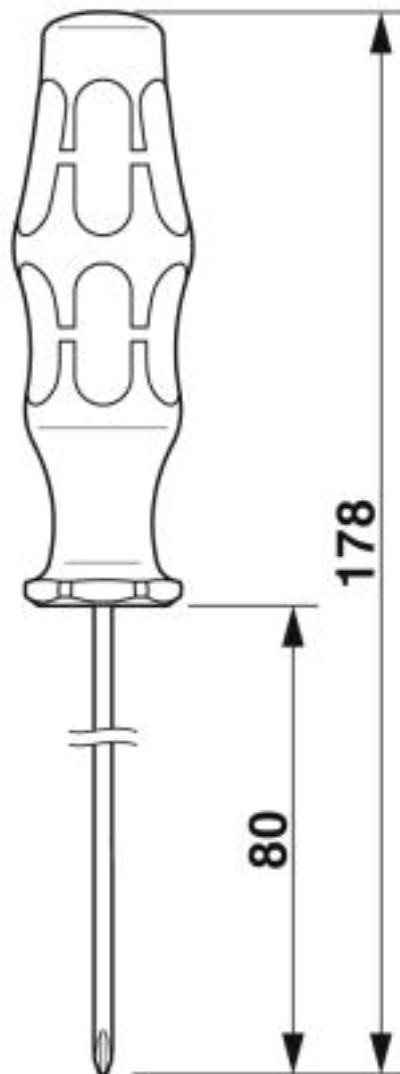

Philips screwdriver - SZK PZ1 VDE - 1206450

Pictogram



Classifications

eCl@ss

| | |
|---------------|----------|
| eCl@ss 10.0.1 | 21040406 |
| eCl@ss 4.0 | 21040400 |
| eCl@ss 4.1 | 21040400 |
| eCl@ss 5.0 | 21040400 |
| eCl@ss 5.1 | 21040400 |
| eCl@ss 6.0 | 21040400 |
| eCl@ss 7.0 | 21040406 |
| eCl@ss 8.0 | 21040406 |
| eCl@ss 9.0 | 21040406 |

Philips screwdriver - SZK PZ1 VDE - 1206450

Classifications

ETIM

| | |
|----------|----------|
| ETIM 2.0 | EC000144 |
| ETIM 3.0 | EC000144 |
| ETIM 4.0 | EC000144 |
| ETIM 5.0 | EC000144 |
| ETIM 6.0 | EC000144 |
| ETIM 7.0 | EC000144 |

UNSPSC

| | |
|---------------|----------|
| UNSPSC 6.01 | 27111701 |
| UNSPSC 7.0901 | 27111701 |
| UNSPSC 11 | 27111701 |
| UNSPSC 12.01 | 27111701 |
| UNSPSC 13.2 | 27111701 |
| UNSPSC 18.0 | 27111701 |
| UNSPSC 19.0 | 27111701 |
| UNSPSC 20.0 | 27111701 |
| UNSPSC 21.0 | 27111701 |

Approvals

Approvals

Approvals

VDE Zeichengenehmigung / EAC

Ex Approvals

Approval details

| | | | |
|------------------------|--|---|--------|
| VDE Zeichengenehmigung | | http://www2.vde.com/de/Institut/Online-Service/VDE-gepruefteProdukte/Seiten/Online-Suche.aspx | 086858 |
|------------------------|--|---|--------|

| | | |
|-----|--|--------------------------|
| EAC | | RU x- DE.xx08.B.02974 |
|-----|--|--------------------------|