

Screwdriver - SZK PH0 VDE - 1205147

Please be informed that the data shown in this PDF Document is generated from our Online Catalog. Please find the complete data in the user's documentation. Our General Terms of Use for Downloads are valid (<http://phoenixcontact.com/download>)



Screwdriver, PH crosshead, VDE insulated, size: PH 0 x 80 mm, 2-component grip, with non-slip grip

Your advantages

- VDE approval
- Screwdrivers for Phillips screws with Pozidriv and Phillips Recess screw head

Key Commercial Data

Packing unit	10 pc
GTIN	 4 017918 019150
GTIN	4017918019150
Weight per Piece (excluding packing)	33.510 g
Weight per piece (including packing)	33.510 g
Custom tariff number	82054000
Country of origin	Czech Republic

Technical data

Dimensions

Length (b)	161 mm
Width (a)	26 mm
Blade width	3 mm
Blade height	80 mm
Wrench size	0 mm

General

Type	Phillips
	straight
Material	alloyed tool steel
Test standard	DIN/ISO 8764-1 PH IEC 60900:2004
Weight	30 g

Standards and Regulations

Test standard	DIN/ISO 8764-1 PH IEC 60900:2004
---------------	----------------------------------

Screwdriver - SZK PH0 VDE - 1205147

Technical data

Environmental Product Compliance

California Proposition 65	Further information on California's prop. 65 is available under "Downloads" in the manufacturer's declaration
---------------------------	---

Drawings

Dimensional drawing

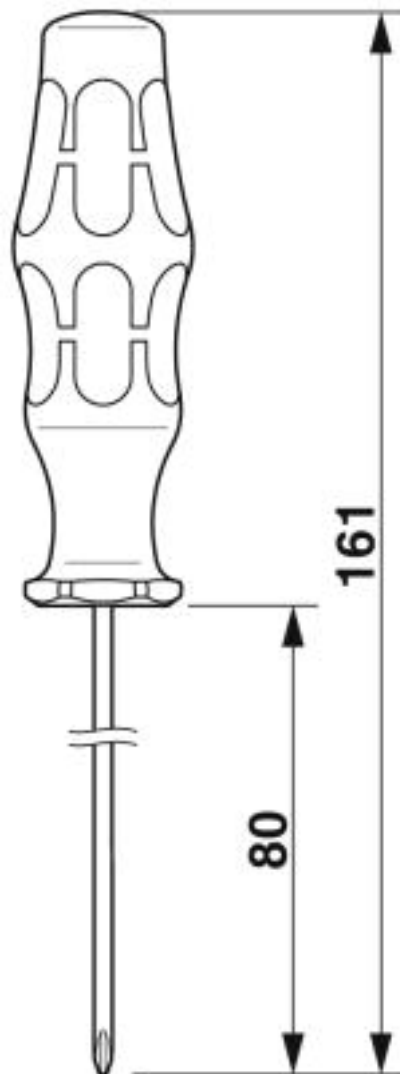

Screwdriver - SZK PH0 VDE - 1205147

Pictogram



Classifications

eCl@ss

eCl@ss 10.0.1	21040406
eCl@ss 4.0	21040400
eCl@ss 4.1	21040400
eCl@ss 5.0	21040400
eCl@ss 5.1	21040400
eCl@ss 6.0	21040400
eCl@ss 7.0	21040406
eCl@ss 8.0	21040406
eCl@ss 9.0	21040406

Screwdriver - SZK PH0 VDE - 1205147

Classifications

ETIM

ETIM 2.0	EC000158
ETIM 3.0	EC000158
ETIM 4.0	EC000144
ETIM 5.0	EC000144
ETIM 6.0	EC000144
ETIM 7.0	EC000144

UNSPSC

UNSPSC 6.01	27111701
UNSPSC 7.0901	27111701
UNSPSC 11	27111701
UNSPSC 12.01	27111701
UNSPSC 13.2	27111701

Approvals

Approvals

Approvals

VDE Zeichengenehmigung / EAC

Ex Approvals

Approval details

VDE Zeichengenehmigung		http://www2.vde.com/de/Institut/Online-Service/VDE-gepruefteProdukte/Seiten/Online-Suche.aspx	086858
------------------------	--	---	--------

EAC		RU x- DE.xx08.B.02974
-----	--	--------------------------